

**THE UNITED REPUBLIC OF TANZANIA
MINISTRY OF HEALTH**



CONTRACT DOCUMENT

FOR

**TENDER NO ME/007/2021-2022/HQ/W/23 FOR PROPOSED
SUPPLY, INSTALLATION AND COMMISSIONING OF ICT
AND SECURITY AT KATAVI. MOH /2021/2022/HQ/W/23**

**CLIENT:
MINISTRY OF HEALTH,
COMMUNITY DEVELOPMENT
GENDER, ELDERLY AND CHILDREN
P.O.BOX 743 DODOMA.**

**CONTRACTOR:
SOFTNET TECHNOLOGIES
P.O. BOX 31918
DAR ES SALAAM**

MARCH, 2022

Form of Contract

This Contract is made on the day of, 2022 between PERMANENT SECRETARY MINISTRY OF HEALTH, P.O. BOX 743, DODOMA (hereinafter called "the Employer") and M/s. SOFTNET TECHNOLOGIES Ltd, P.O. BOX 31918 DAR ES SALAAM (hereinafter called "the Contractor") of the other part.

Whereas the Employer is desirous that the Contractor execute Contract for Tender NO:ME/007/2021-2022/W/23 For Proposed Supply, Installation and Commissioning of ICT and Security at Katavi (RRH) Hospital (hereinafter called "the Works") and the Employer has accepted the Bid by the Contractor for the execution and completion of such works and the remedying of any defects therein in the sum of Tanzania shillings **Nine hundred Forty-Eight Million Seven Hundred Fifty-four Thousand Nine Hundred Fifty Seven Seventy Nine Cents Only (948,754,957.79) VAT Inclusive** (hereinafter called "Contract Price").

Now this Contract witnesses as follows:

1. In this Contract, words and expressions shall have the same meanings as are respectively assigned to them in the Conditions of Contract hereinafter referred to, and they shall be deemed to form and be read and construed as part of this Agreement.
2. The following documents attached hereto shall be deemed to form an integral part of this Contract:
 - i. Form of Contract
 - ii. Form of Tender
 - iii. Special Condition of Contract
 - iv. General Condition of Contract
 - v. Letter of Notification to award
 - vi. Letter of Acceptance
 - vii. Negotiation minutes
 - viii. Priced Bill of Quantities
 - ix. Drawings.
3. All the aforesaid documents are hereinafter referred to as "the Contract" and shall be taken as complementary and mutually explanatory of one another but in case of ambiguities or discrepancies shall take precedence in the order set out above.
4. In consideration of the payments to be made by the Employer to the Contractor as hereinafter mentioned, the Contractor hereby covenants with the Employer to execute and complete the Works and remedy any

ym

defects therein in conformity in all respects with the provisions of the Contract.

5. the Employer hereby covenants to pay the Contractor in consideration of the execution and completion of the Works and the remedying of defects wherein the Contract Price or such other sum **Nine hundred Forty-Eighty Million Seven Hundred Fifty-four Thousand Nine Hundred Fifty-Seven Seventy-Nine Cents Only (948,754,957.79) VAT Inclusive for the period of 7 months.** as may become payable under the provisions of the Contract at the times and in the manner prescribed by the Contract.

IN WITNESS whereof the parties thereto have caused this Contract to be executed the day and year first before written.

For and on behalf of the Ministry of Health

.....
Signature of Authorized representative
Name Prof. Abel N. Makubi
Occupation Permanent Secretary

In the presence of

Signature.....
Name RASHID A. MASHOMBO
Occupation Acting Director Legal Services

For and on behalf of Messrs SOFTNET TECHNOLOGIES Ltd, P.O. BOX 31918 DAR ES SALAAM

.....
Signature of Authorized representative
Name YUSUPH MWAKIMWAAGILE
Occupation HOD ICT FACILITIES

In the presence of

Signature.....
Name Stam Ahy Mwakimwa
Occupation Advocate



2. Form of Tender

17th January, 2022

To: **MINISTRY OF HEALTH, COMMUNITY DEVELOPMENT, GENDER, ELDERLY AND CHILDREN**

We **SOFTNET TECHNOLOGIES LTD**, offer to execute the **TENDER NO: ME/007/2021-2022/HQ/W/23 PROPOSED SUPPLY, INSTALLATION AND COMMISSIONING OF ICT AND SECURITY INSTALLATION WORKS FOR THE COMPLETION CONSTRUCTION OF KATAVI RRH - OPD, DIAGNOSTIC CENTRE AND MATERNITY WING AT MPANDA MUNICIPALITY, KATAVI REGION TANZANIA** in accordance with the Conditions of Contract accompanying this Tender for the Contract Price of **967,635,653.47, VAT INCLUSIVE [Nine hundred sixty seven million six hundred thirty five thousand six hundred fifty three shillings forty seven cents] Tanzanian shillings.**

The Contract shall be paid in the following currencies:

Currency	Percentage payable in currency	Rate of exchange: one foreign equals [insert local]	Inputs for which foreign currency is required
(a)	TZS	N/A	N/A
(b)			

The advance payment required is:-

Amount	Currency
(a)	
(b)	

We declare that our tendering price did not involve agreements with other tenderers for the purpose of tender suppression.

We hereby confirm whoever that shall be **APPOINTED BY NATIONAL CONSTRUCTION COUNCIL** ,to be the Appointing Authority, to appoint the adjudicator in case of any arisen disputes in accordance with ITT 43.1 [Adjudicator]

We are not participating, as tenderers, in more than one Tender in this tendering process other than alternative tenders in accordance with the tendering documents.

Ym

We declare that, as tenderer(s) we do not have conflict of interest with reference to ITT 3.7 [Eligibility of Tenderers]

With reference to ITT 3.11 [Eligibility of Tenderers], it is our intention to subcontract approximately N/A percentage of the Tender /Contract Price, details of which are provided herein.

Our firm, its affiliates or subsidiaries, including any subcontractors or suppliers for any part of the contract has not been declared ineligible by the Government of the United Republic of Tanzania under Tanzania's laws or official regulations or by an act of compliance with a decision of the United Nations Security Council.

The following commissions or gratuities of fees have been paid or are to be paid by us to agents relating to this tender, and to contract execution if we are awarded the contract:-

Name and address of agent or recipient	Amount and currency	Purpose of commission or gratuity
NONE	NONE	NONE

(if none has been paid or is to be paid, state "none")

This tender and your written acceptance of it shall constitute a binding Contract between us.

We understand that you are not bound to accept the lowest or any Tender you receive.

We hereby confirm that this tender complies with the tender validity and Tender Security required by the tendering documents and specified in the Tender Data Sheet.

Authorized Signature:



Name and Title of Signatory: YUSUPH MWAKIMWAGILE - HOD ICT FACILITIES

Name of Tenderer: SOFTNET TECHNOLOGIES LTD

Address: 31918, DAR ES SALAAM

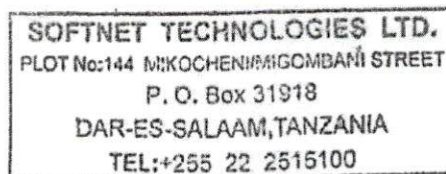

Ym

SPECIAL CONDITIONS OF CONTRACT

Special Conditions of Contract (SCC)

Instructions for completing the Special Conditions of Contract

The following Special Conditions of Contract shall supplement the General Condition of Contract. Whenever there is a conflict, the provisions herein shall prevail over those in the General Conditions of Contract. Except where otherwise indicated, all Special Conditions of Contract should be filled in by the Employer prior to issuance of the Tendering Documents. Schedules and reports to be provided by Employer should be annexed.

SCC Clau se	GCC Clau se	Description
1.	1.1	<p>Defect Liability Period will be Twelve Month (12)</p> <p>The Employer is Permanent Secretary, Ministry of Health.</p> <p>The Project Manager is Arch. Linda Kasilima, Crystal Consultants, P.o. Box 75068, Dar es Salaam.</p> <p>The Works consist of;</p> <ul style="list-style-type: none"> - Provide for installation of Structured Cabling (VoIP) - Provide for installation of CCTV Camera Installation - Supply and installation of Access Control (IP BASED) - Provide for installation of Fire Detection System - Provide for installation of TV Networking - Provide for installation of Nurse Call System <p>The Commencement Date shall be 7 days after signing the contract.</p> <p>The Intended Completion Date for the whole of the Works shall be 7 months</p> <p>The Site is located at Mpanda Municipality, Katavi region,</p>

		Tanzania.
2	2.2	Indicate whether sectional completion is specified. Wing 'A' shall be handed over when completed, prior to completion date of the project
3	2.3	List other documents that form part of the contract if any: a) Form of Contract b) Form of Tender c) Special Condition of Contract d) General Condition of Contract e) Letter of Notification to award f) Letter of Acceptance g) Negotiation minutes h) Priced Bill of Quantities i) Drawings.
4	4.1	The language of the Contract documents is English . The law that applies to the Contract is the Laws of Tanzania
5	7.1	Address for communication Employer's: Permanent Secretary, Ministry of Health, P. o Box 743, 40478, Dodoma. Contractor: Messrs softnet technologies ltd, p.o. box 31918 Dar Es Salaam
6	11.1	Include the Schedule of Other Contractors if any NOT APPLICABLE
7	12.1	Include the Schedule of Key Personnel <ul style="list-style-type: none"> • Site Agent [ICT Engineer] • Site ICT Engineer • Foreman/ICT Technician

8	16.1	<p>The minimum insurance covers shall be:</p> <ul style="list-style-type: none"> (a) loss of or damage to the Works, Plant, and Materials [Tzs. 50,000,000.00]; (b) loss of or damage to Equipment [Tzs. 50,000,000.00]; (c) loss of or damage to property (except the Works, Plant, Materials, and Equipment) in connection with the Contract [Tzs. 100,000,000.00]; and (d) personal injury or death [Tzs. 100,000,000.00];
9	17.1	Site Investigation Reports available to the Tenderer are:
	24.1	N/A
10.	25.4	<p>The other measures include:</p> <ul style="list-style-type: none"> a) Minimising the number of migrant workers employed on the project and household in the site camp b) Providing access to voluntary counseling and testing (VCT) c) Providing psychological support and health care including prevention and treatment of opportunistic infections for workers infected and affected, as well as their families d) Providing condoms (male and female) to workers
11.	27.1	The Site Possession Date shall be 7 days after Contract sign
	30.1	Appointing Authority for the Adjudicator is The National Construction Council (NCC) of Tanzania
	30.3	Party is dissatisfied with the Adjudicator's decision may, within 28 days refer the dispute for arbitration

	30.4	Arbitration will take place at DODOMA in accordance with rules and regulations published by NATIONAL CONSTRUCTION COUNCIL
12.	31.1	Hourly rate of Fees payable to the Adjudicator shall be determined by National Construction Council Rules and Regulations. In accordance with the published rules of NCC. Types of reimbursable expenses to be paid to the Adjudicator include: a) Transport. b) Stationaries.
13.	32.1	Appointing Authority for the Adjudicator: NATIONAL CONSTRUCTION COUNCIL (NCC)
	33.1	Appointed Contractor will be responsible for the security of the site.
		B. Time Control
14.	34.1	The Contractor Shall Submit a revised Program for the Works within 30 days of delivery of the Letter of Acceptance.
15.	34.2	The period between Programme updates is Sixty (60) days . The amount to be withheld Project Manager in the case the contractor does not submit an updated programme is: Tzs 10,000,000.00.
C. Quality Control		
16.	42.1	The Defects Liability Period is 365 days .

D. Cost Control		
17.	46.1	No rate adjustment allowed in accordance to GCC 46.
	46.2	No rate adjustment allowed in accordance to GCC 46.
18.	50.7	Minimum amount of Interim Payment Certificate will be Tzs 50,000,000.00.
19.	53.1	Site Possession date shall: 7 days after contract sign
20.	52.1	The currency is Tanzania Shillings
21.	55.1	The contract IS NOT subject to price adjustment in accordance with GCC 55.
22.	56.1	The amount of retention is Ten (10) percent of value of works of Interim Payment Certificate'. Limit of retention: Five (5) percent of contract price
23.	57.1	(i) The amount of liquidated damages per day is 0.1 percent of Contract Price per day (ii) The maximum amount of liquidated damages is 10% of the Contract Price.
24.	58.1	The Bonus for early completion: Not Applicable.
25.	59.1	The Advance Payment shall be fifteen (15) percent of the Contract Price. This will be paid upon submission of Unconditional Bank Guarantee . The advance payment recovery will be as follows; 1. When works progress is 20%, the recovery will be 20% 2. When works progress is 30%, the recovery will be 33%

	59.3	<p>3. When works progress is 40%, the recovery will be 47%</p> <p>4. When works progress is 50%, the recovery will be 60%</p> <p>5. When works progress is 60%, the recovery will be 73%</p> <p>6. When works progress is 70%, the recovery will be 87%</p> <p>7. When works progress is 80%, the recovery will be 100%</p> <p>Monthly Recovery of Advance Payments will be 20 % of the amount of Interim Payment or any percentage such that advance payment is fully recovered by the time that, 80% of value of works in contract is completed</p>
26.	60.1	<p>The Performance Security shall be the minimum amounts equivalent to Ten (10) percent for Bank Guarantee of the contract price in the form of:</p> <p>(a) Unconditional Bank Guarantee The standard form of Performance Security acceptable to the Employer shall be Unconditional Bank Guarantee as preferred by the Employer of the type presented in Section IX of the Tendering Documents.</p>
27	64.1	<p>Site handover date be is When the Certificate of Completion is issued by the Project Manager, the Contractor shall handover the site and the works to the Employer</p>
E. Discharge of the Contract		
28	66.2	<p>The amount to be withheld for failing to produce "as built" drawings by the date required is Tzs 25,000,000.00.</p> <p>The amount to be withheld for failing to produce operating and maintenance manuals by the date required is Tzs 25,000,000.00.</p>
29	67.2 (C) 67.2 (h)	<p>contractor's failure to submit performance security within 28 days</p> <p>The Contractor has delayed the completion of the Works by the number of days for which the maximum amount of</p>

		liquidated damages can be paid is 0.1%
30	68.1	The percentage to apply to the value of the work not completed, representing the Employer's additional cost for completing the Works, is 15%.

GENERAL CONDITIONS OF CONTRACT

Table of Clauses

Sec. IV

A. General13

1. Definitions.....13

2. Interpretation.....17

3. Conditions Precedent18

4. Language and Law18

5. Project Manager’s Role.....18

6. Delegation18

7. Communications18

8. Sub contracting.....20

9. Assignment20

10. Liability of Joint Venture.....20

11. Other Contractors20

12. Personnel20

13. Employers and Contractor's Risks.....21

14. Employers Risks.....21

15. Contractor's Risks22

16. Insurance22

17. Site Investigation Reports.....23

18. Queries about Implementation of the Contract.....23

19. Contractor to Execute the Works.....23

20. Commencement and Completion of Works23

21.	Approval by the Project Manager	23
22.	Protection of the environment	24
23.	Labour Laws	24
24	Taxes and Duties	24
25.	Health and Safety	24
26.	Discoveries	26
27.	Possession of the Site	26
28.	Access to the Site	26
29.	Instructions, inspections and audits.....	26
30.	Disputes Resolution.....	26
31.	Fees and Costs of Adjudicator	28
32.	Replacement of Adjudicator.....	28
33.	Security of the Site	28
 B. Time Control		28
34.	Program.....	29
35.	Extension of the Intended Completion Date.....	30
36.	Acceleration	30
37.	Delays Ordered by the Project Manager	31
38.	Management Meetings.....	31
39.	Early Warning Notice.....	32
 C. Quality Control.....		33

40. Identifying Defects.....33

41. Tests33

42. Correction of defects.....33

43. Extension of Defect Liability Period.....33

44. Uncorrected Defects.....34

D. Cost Control.....34

45. Bill of Quantities.....34

46. Changes in the Quantities.....34

47. Variations35

48. Payments for Variations.....35

49. Cash Flow Forecasts36

50. Payment Certificates.....36

51. Payments38

52. Currencies39

53. Compensation Events.....39

54. Effect of Changes in Tax Laws42

55. Price Adjustment.....42

56. Retention46

57. Liquidated Damages.....47

58. Bonus48

59.	<u>Advance Payment</u>	48
60.	<u>Performance Securities</u>	49
61.	<u>Day-works</u>	50
62.	<u>Cost of Repairs</u>	50
 <u>E. Discharge of the Contract</u>		50
63.	<u>Completion Certificate</u>	51
64.	<u>Site Hand Over</u>	51
65.	<u>Final Account</u>	51
66.	<u>Operating and Maintenance Manuals</u>	51
67.	<u>Termination</u>	52
68.	<u>Payment upon Termination of Contract</u>	55
69.	<u>Property</u>	56
70.	<u>Suspension of Financing</u>	56
71.	<u>Force Majeure</u>	56
72.	<u>Release from Performance</u>	58

A. General

1. Definitions	1.1 <p>The following words and expressions shall have the meanings hereby assigned to them:</p> <p>The Adjudicator is the person appointed by the Appointing Authority specified in the SCC to resolve contractual disputes in the first instance, and as provided for in GCC 30 [Disputes Resolution] hereunder.</p> <p>The Arbitrator is the person appointed by the Appointing Authority specified in the SCC to resolve contractual disputes, and as provided for in GCC 30 [Disputes Resolution] hereunder.</p> <p>Bill of Quantities -means the priced and completed Bill of Quantities forming part of the Tender.</p> <p>Compensation Events are those events provided for in GCC 53 [Compensation Events]</p> <p>The Completion Date is the date of completion of the Works as certified by the Project Manager, in accordance with GCC 63.1 [Completion Certificate].</p> <p>The Contract is the agreement entered between the Employer and the Contractor to execute, complete, and maintain the Works. It consists of the documents listed in GCC 2.3 [Interpretation] below.</p> <p>The Contractor is the person, whether natural or legal whose tender to carry out the Works has been accepted by the Employer.</p> <p>The Contractor's Tender is the completed Tender document submitted by the Contractor to the Employer.</p> <p>The Contract Price is the price stated in the Letter of Acceptance and thereafter as adjusted in accordance</p>
----------------	--

	<p>with the provisions of the Contract.</p> <p>Days are calendar days.</p> <p>Day-works are varied work inputs subject to payment on a time basis for the Contractor's employees and Equipment, in addition to payments for associated Materials and Plant.</p> <p>A Defect is any part of the Works not completed in accordance with the Contract.</p> <p>The Defects Liability Certificate is the certificate issued by Project Manager upon correction of defects by the Contractor at the end of defect liability period.</p> <p>The Defects Liability Period is the period stated in the Special Conditions of Contract and calculated from the Completion Date.</p> <p>Drawings means the drawings of the works, as included in the contract and any additional or modified drawings issued by (or on behalf of) the employer in accordance with the contract</p> <p>Effective Contract date is the date shown in the Certificate of Contract Commencement issued by the Employer upon fulfilment of the conditions precedent stipulated in GCC 3 [Conditions Precedent].</p> <p>The Employer means the person named as employer in the SCC and the legal successors in title to this person.</p> <p>Equipment is the Contractor's machinery and vehicles brought to the Site to execute the Works.</p> <p>The Commencement Date is the date when the Contractor shall commence execution of the Works as specified in the Certificate of Contract Commencement.</p>
--	--

	<p>The Commencement Date may be revised by the Project Manager in consultation with the employer by issuing an extension of time.</p> <p>The Intended Completion Date is the date on which it is intended that the Contractor shall complete the Works as specified in the Special Conditions of Contract.</p> <p>Materials are all supplies, including consumables, used by the Contractor for execution of the Works.</p> <p>Months mean calendar months.</p> <p>Plant is any integral part of the Works that shall have a mechanical electrical, chemical, or biological function.</p> <p>The Project Manager is the person named in the Special Conditions of Contract (or any other competent person appointed by the Employer and notified to the Contractor, to act in replacement of the Project Manager) who is responsible for supervising the execution of the Works and administering the Contract.</p> <p>The Site is the area where works are to be executed as specified in the SCC.</p> <p>Site Investigation Reports are factual and interpretative reports about the surface and subsurface conditions at the Site that were included in the Tendering documents as indicated in the SCC.</p> <p>Specification means the Specification of the Works included in the Contract and any modification or</p>
--	--

addition made or approved by the Project Manager.

A **Subcontractor** is a person, whether natural or legal, who has a Contract with the Contractor to carry out a part of the work in the Contract, which includes work on the Site.

Temporary Works are works designed, constructed, installed, and removed by the Contractor that are needed for construction or installation of the Works.

A **Variation** is an instruction given by the Project Manager in consultation with the Employer, which varies the Works.

Force Majeure means an unforeseeable event which is beyond reasonable control of either Party and which makes a Party's performance of its obligations under the Contract impossible or so impractical as to be considered impossible under the circumstances. For the purposes of this Contract, "Force Majeure" means an event which is beyond the reasonable control of a Party, is not foreseeable, is unavoidable, and its origin is not due to negligence or lack of care on the part of a Party, and which makes a Party's performance of its obligations hereunder impossible or so impractical as reasonably to be considered impossible in the circumstances and includes, but is not limited to, war, riots, civil disorder, earthquake, fire, explosion, storm, flood, epidemics, or other adverse weather conditions, strikes, lockouts or other industrial action (except where such strikes, lockouts or other industrial action are within the power of the Party invoking Force Majeure to prevent), confiscation.

The **Works** are what the Contract requires the Contractor to construct, install, and turn over to the Employer, as defined in the SCC.

2. Interpretation	2.1	In interpreting these Conditions of Contract headings and marginal notes are used for convenience only and shall not affect their interpretations unless specifically stated; references to singular include the plural and vice versa; and masculine include the feminine.. Words have their ordinary meaning under the language of the Contract unless specifically defined.
	2.2	If sectional completion is specified in the Special Conditions of Contract , references in the Conditions of Contract to the Works, the Completion Date, and the Intended Completion Date apply to any Section of the Works (other than references to the Completion Date and Intended Completion Date for the whole of the Works).
	2.3	<p>The documents forming the Contract shall be interpreted in the following order of priority:</p> <ol style="list-style-type: none"> (1) Form of Agreement, (2) Special Conditions of Contract, (3) General Conditions of Contract, (4) Letter of Acceptance, (5) Certificate of Contract Commencement, (6) Specifications, (7) Drawings, (8) Bill of Quantities, (9) Contractor's Tender, and (10) Any other document listed in the Special Conditions of Contract as forming part of the Contract.

3. Conditions Precedent	3.1	Having signed the Contract, it shall come into effect on the date on which the following conditions have been satisfied:- a) Submission of performance Security in the form specified in the SCC; and b) Furnishing of Advance Payment (if any) Unconditional Guarantee.
	3.2	If the Employer is satisfied that each of the conditions precedent in this contract has been satisfied (except to the extent waved by him, but subject to such conditions as he shall impose in respect of such waiver)he shall promptly issue to the contractor a certificate of Contract commencement, which shall confirm the start date.
	3.3	If the Conditions precedent stipulated on GCC 3.2 is not met by the date specified in the SCC this contract shall not come into effect;
4. Language and Law	4.1	The language of the Contract and the law governing the Contract are stated in the SCC.
5. Project Manager's Role	5.1	Except where otherwise specifically stated, the Project Manager will supervise execution of the contract between the Employer and the Contractor. The Project Manager shall have no authority to amend the contract.
6. Delegation	6.1	The Project Manager may, upon prior written consent of the employer and after notifying the contractor, delegate any of his duties and responsibilities to other people except to the Adjudicator, and may cancel any delegation after notifying the Contractor.
7. Communications	7.1	Communications between the Parties to the Contract shall be effective only when in writing whether in hard or electronic form that provides record of the content of the communication. A notice shall be effective when in writing only when it is delivered at the address specified

		in the SCC.
--	--	-------------

8. Sub contracting	8.1	The Contractor may subcontract with the approval of the Project Manager, subject to consultation with the Employer. Subcontracting shall not alter the Contractor's obligations
9. Assignment	9.1	The Contractor shall not assign, transfer, pledge or make other disposition of this Contract or any part thereof or any of the contractor's rights, claim or obligation under this Contract without the prior written approval of the Employer.
10. Liability of Joint Venture	10.1	<p>If the Contractor constitutes a joint venture, consortium or other unincorporated grouping of two or more persons:</p> <ul style="list-style-type: none"> (a) These persons shall be jointly and severally liable to the Employer for the performance of the Contract; (b) These person shall notify the Employer of their leader who shall have the authority to bind the Contractor and each of these persons; and (c) The Contractor shall not alter its composition or legal status without the prior consent of the Employer.
11. Other Contractors	11.1	The Contractor shall cooperate and share the Site with other contractors, public authorities, utilities, and the Employer between the dates given in the Schedule of Other Contractors, as referred to in the SCC. The Contractor shall also provide facilities and services for them as described in the Schedule. The Employer may modify the Schedule of Other Contractors, and shall notify the Contractor of any such modification.
12. Personnel	12.1	The Contractor shall employ the key personnel named in the Schedule of Key Personnel, as referred to in the SCC, to carry out the functions stated in the Schedule or other personnel approved by the Project Manager. The Project

		Manager will approve any proposed replacement of key personnel only if their relevant qualifications and abilities are substantially equal to or better than those of the personnel listed in the Schedule.
	12.2	If the Project Manager asks the Contractor to remove a person who is a member of the Contractor's staff or work force, stating the reasons for, the Contractor shall ensure that the person leaves the Site within seven days and has no further connection with the work in the Contract.
13. Employers and Contractor's Risks	13.1	The Employer carries the risks which this Contract states are Employer's risks, and the Contractor carries the risks which this Contract states are Contractor's risks.
14. Employers Risks	14.1	<p>From the Commencement Date until the Defects Correction Certificate has been issued, the following are Employer's risks:</p> <p>(a) The risk of personal injury, death, or loss of or damage to property (excluding the Works, Plant, Materials, and Equipment), which are due to:</p> <p>(i) use or occupation of the Site for the purpose of the Works, which is the unavoidable result of the Works or</p> <p>(ii) negligence, breach of statutory duty, or interference with any legal right by the Employer or by any person employed by or contracted to him except the Contractor.</p> <p>(b) The risk of damage to the Works, Plant, Materials, and Equipment to the extent that it is due to a fault of the Employer or in the Employer's design.</p>
	14.2	From the Completion Date until the Defects Correction Certificate has been issued, the risk of loss or damage to the Works, Plant, and Materials is an Employer's risk except loss or damage due to:

		<p>(a) a Defect which existed on the Completion Date,</p> <p>(b) an event occurring before the Completion Date, which was not itself an Employer's risk, or</p> <p>(c) the activities of the Contractor on the Site after the Completion Date.</p>
15. Contractor's Risks	15.1	From the Commencement Date until the Defects Correction Certificate has been issued, the risks of personal injury, death, and loss of or damage to property (including, without limitation, the Works, Plant, Materials, and Equipment) which are not Employer's risks are Contractor's risks.
16. Insurance	16.1	<p>The Contractor shall provide, in the joint names of the Employer and the Contractor, insurance cover from the Commencement Date to the end of the Defects Liability Period, in the amounts and deductibles stated in the SCC for the following events which are due to the Contractor's risks:</p> <p>(a) loss of or damage to the Works, Plant, and Materials;</p> <p>(b) loss of or damage to Equipment;</p> <p>(c) loss of or damage to property (except the Works, plant, Materials, and Equipment) in connection with the Contract; and</p> <p>(d) personal injury or death.</p>
	16.2	Policies and certificates for insurance shall be delivered by the Contractor to the Project Manager for the Project Manager's approval before the Commencement Date. All such insurance shall provide for compensation to be payable in the types and proportions of currencies required to rectify the loss or damage incurred.
	16.3	If the Contractor does not provide any of the policies and certificates required, the Employer may effect the insurance which the Contractor should have provided

		and recover the premiums the Employer has paid from payments otherwise due to the Contractor or, if no payment is due, the payment of the premiums shall be a debt due.
	16.4	Alterations to the terms of an insurance shall not be made without the written approval of the Project Manager.
	16.5	Both parties shall comply with any conditions of the insurance policies.
17. Site Investigation Reports	17.1	The Contractor shall, in executing the contract, rely on Site Investigation Reports referred to in the SCC and any supplemented information available to the Contractor.
18. Queries about Implementation of the Contract	18.1	The Project Manager will clarify queries on all Contractual matters.
19. Contractor to Execute the Works	19.1	The Contractor shall execute and install the Works in accordance with the terms and conditions of the Contract.
20. Commencement and Completion of Works	20.1	The Contractor may commence execution of the Works by the Commencement Date and shall carry out the Works in accordance with the Works Program submitted by the Contractor, as updated with the approval of the Project Manager, and complete them by the Intended Completion Date.
21. Approval by the Project Manager	21.1	The Contractor shall submit Specifications and Drawings showing the proposed Temporary Works to the Project Manager, who is to approve them if they comply with the Specifications and Drawings.
	21.2	The Contractor shall be responsible for design of Temporary Works.
	21.3	The Project Manager's approval shall not alter the Contractor's responsibility for design of the Temporary

		Works.
	21.4	The Contractor shall obtain approval of third parties to the design of the Temporary Works, where required.
	21.5	All Drawings prepared by the Contractor for the execution of the temporary or permanent Works, are subject to prior approval by the Project Manager.
22. Protection of the environment	22.1	The Contractor shall take all reasonable steps to protect the environment and to limit damage and nuisance to people and property resulting from pollution, noise and other results of his operations.
	22.2	The Contractor shall ensure that emissions, surface discharges and effluent from his activities shall not exceed limits prescribed in relevant environmental laws.
23. Labour Laws	23.1	The Contractor shall comply with all the relevant labour laws applicable in the United Republic of Tanzania, including laws relating to workers employment, social security, working hours, health, safety, welfare and immigration.
	23.2	The Contractor shall require his employees to obey all applicable laws, including those concerning safety at work.
24. Taxes and Duties	24.1	The Contractor, Sub-contractors and Personnel shall pay such taxes, duties, fees and other impositions as may be levied under the Laws of Tanzania unless otherwise stated in the SCC.
25. Health and Safety	25.1	The Contractor shall at all times take all reasonable precautions to maintain the health and safety of his personnel and the public as per the governing occupational, health and safety laws
	25.2	The Contractor shall ensure that first aid facilities are available at all times at the site and that suitable

		arrangements are made for all necessary welfare and hygiene requirements and for the prevention of epidemics
	25.3	The Contractor shall notify the Employer details of any accident as soon as practicable after its occurrence. The Contractor shall maintain records and make reports concerning health, safety, and welfare of persons, and damage to the property, as the Employer may reasonably require.
	25.4	The Contractor shall conduct an HIV-AIDS awareness programme, and shall take other such measures as specified in the SCC to reduce the risk of transfer of HIV virus between and among Contractor's personnel, the Employers Staff and the surrounding community.

26. Discoveries	26.1	Anything of historical or other interest or of significant value unexpectedly discovered on, in, or under the land at the Site shall be the property of the Employer.
	26.2	The Contractor shall notify the Project Manager of such discoveries and carry out the Project Manager's instructions for dealing with them.
	26.3	The Contractor shall take reasonable precautions to prevent his workers or any other persons from damaging such discoveries and shall immediately upon discovery thereof and before removal acquaint the Project Manager of such discovery and carry out at the expense of the Employer the instructions of the Project Manager.
27. Possession of the Site	27.1	The Employer may give possession of whole or parts of the Site to the Contractor as stated in the SCC. If possession is not given by the date stated in the SCC, the Employer will be deemed to have delayed the start of the relevant activities, and this will be a Compensation Event.
28. Access to the Site	28.1	The Contractor shall allow the Project Manager and any person authorized by the Project Manager access to the Site and to any place where work in connection with the Contract is being carried out or is intended to be carried out.
29. Instructions, inspections and audits	29.1	The contractor shall comply with instructions given by the Project Manager in writing on any matter related to the contract
	29.2	The Contractor shall permit the Government, of the United Republic of Tanzania to inspect the Contractor's accounts and records relating to the performance of the Contract and to have them audited by auditors appointed by the Government of the United Republic of Tanzania if so required.
30. Disputes Resolution	30.1	In the event of any dispute arising out of this contract, either party shall issue a notice of dispute to settle the

		<p>dispute amicably. The parties hereto shall, within twenty-eight (28) days from the notice date, use their best efforts to settle the dispute amicably through mutual consultations and negotiation. Any unsolved dispute may be referred by either party to an adjudicator nominated by the appointing Authority specified in the SCC.</p>
	30.2	<p>After the dispute has been referred to the adjudicator, within 30 days, or within such other period as may be proposed by the Parties, the Adjudicator shall give its decision. The rendered decision shall be binding to the Parties.</p>
	30.3	<p>If either Party is dissatisfied with the Adjudicator's decision may, within days specified in the SCC refer the dispute for arbitration. If either party within the period mentioned in the SCC has not referred the matter for arbitration the decision shall become final and binding to the Parties.</p>

	30.4	The arbitration shall be conducted in accordance with the arbitration procedure published by the Institution named and in the place shown in the SCC .
31. Fees and Costs of Adjudicator	31.1	The rate of the Adjudicator's fee and administrative costs of adjudication shall be borne equally by the Parties. The rates and costs shall be in accordance with the rules of the Appointing Authority. In conducting adjudication to its finality each party shall bear its incurred costs and expenses.
32. Replacement of Adjudicator	32.1	Should the Adjudicator resign or die, or should the Employer and the Contractor agree that the Adjudicator is not functioning in accordance with the provisions of the Contract; a new Adjudicator will be appointed by the Appointing Authority.
33. Security of the Site	33.1	Unless otherwise stated in the SCC , (a) the Contractor shall be responsible for keeping unauthorised persons off the site, and (b) authorised persons shall be limited to the Contractor's and Employer's personnel, and to any other personnel and other Contractor notified to the Contractor by the Project Manager or Employer.
		B. Time Control

34. Program	34.1	Within the time stated in the SCC, the Contractor shall submit to the Project Manager for approval of the Work Program showing the method(s), arrangements, order and timing for all the activities of the Works.
	34.2	The Contractor shall submit to the Project Manager for approval an updated Works Program at intervals not longer than the period stated in the SCC. If the Contractor does not submit an updated Works Program within this period, the Project Manager may withhold the amount stated in the SCC from the next payment certificate and continue to withhold this amount until the next payment after the date on which the overdue Program has been submitted.
	34.3	An update of the Works Program shall be a program showing the actual progress achieved on each activity and the effect of the progress achieved on the timing of the remaining work, including any changes to the sequence of the activities.
	34.4	The Project Manager's approval of the Program shall not alter the Contractor's obligations. The Contractor may revise the Program and submit it to the Project Manager again at any time. A revised Program shall show the effect of Variations and Compensation Events if any.

35. Extension of the Intended Completion Date	35.1	The Employer may extend the Intended Completion Date if a Compensation Event occurs or a Variation is issued which makes it impossible for Completion to be achieved by the Intended Completion Date without the Contractor taking steps to accelerate the remaining work, which would cause the Contractor to incur additional cost.
	35.2	The Employer shall, within twenty one (21) days of receipt of application for extension of the Intended Completion Date by the Contractor, decide whether or not to grant the extension. The application by the Contractor shall be granted only when supported by full information of a compensations event(s) or variation.
	35.3	In the event the Contractor has not issued an early warning notice of a delay or has failed to cooperate in dealing with a delay, such a delay or failure may be a ground for not granting the extension of the Intended Completion Date.
36. Acceleration	36.1	When the Employer wants the Contractor to finish the Works before the Intended Completion Date, the Project Manager will obtain priced proposals for achieving the necessary acceleration from the Contractor. If the Employer accepts the said proposals, the Intended Completion Date will be adjusted accordingly and confirmed by both the Employer and the Contractor.
	36.2	in the event the Contractor's priced proposals for acceleration of the Works are accepted by the Employer, they shall be incorporated in the Contract Price and

		treated as a Variation.
37. Delays Ordered by the Project Manager	37.1	The Project Manager may instruct the Contractor to delay the start or progress of any activity within the Works.
38. Management Meetings	38.1	Either the Project Manager or the Contractor may require the other to attend a management meeting. The business of a management meeting shall be to review the plans for remaining work and to deal with matters raised in accordance with the early warning procedure.
	38.2	The Project Manager shall record the business of management meetings and provide copies of the record to those attending the meeting and to the Employer. The responsibility of the parties for actions to be taken shall be decided by the Project Manager either at the management meeting or after the management meeting and stated in writing to all who attended the meeting.

39. Early Warning Notice	39.1	The Contractor shall give an early warning notice to the Project Manager at the earliest opportunity of specific likely future event(s) or circumstance(s) that may adversely affect the quality of the Works, increase the Contract Price or delay the execution of the Works. Upon receipt of the said Notice, the Project Manager may require the Contractor to provide an estimate of the expected effect of the future event(s) or circumstance(s) on the Contract Price and Intended Completion Date or Completion Date as the case may be. The estimate shall be provided by the Contractor as soon as reasonably possible.
	39.2	The Contractor shall cooperate with the Project Manager in making and considering proposals on how the effect of such an event(s) or circumstance(s) could be avoided or reduced by anyone involved in the Works and in carrying out any resulting Instruction of the Project Manager.

C. Quality Control		
40. Identifying Defects	40.1	The Project Manager shall check the Contractor's work and notify the Contractor of any Defects that are found. Such checking shall not affect the Contractor's responsibilities.
	40.2	The Project Manager may instruct the Contractor to search for a Defect and to uncover and test any work that the Project Manager considers may have a Defect.
41. Tests	41.1	The Project Manager may instruct the Contractor to carry out a test not specified in the Specification to check whether any work has a Defect and in the event the test shows that it does, the Contractor shall pay for the test and any samples thereof. If there is no Defect, the test shall be a Compensation Event.
42. Correction of Defects	42.1	The Project Manager shall give notice to the Contractor of any Defects before the end of the Defects Liability Period stated in the SCC, which begins from the Completion Date. .
43. Extension of Defect Liability Period	43.1	Every time notice of a Defect is given, the Contractor shall correct the notified Defect(s) within the period of time specified in the Project Manager's notice.
	43.2	The Defects Liability Period may be extended by the

		Project Manager for as long as Defects remain to be corrected.
44. Uncorrected Defects	44.1	In the event the Contractor has not corrected a Defect(s) within the time specified in the Project Manager's notice, the Project Manager will assess the cost of having the Defect corrected, including any other related cost(s) and the Contractor will pay the said cost.
		D. Cost Control
45. Bill of Quantities	45.1	The Bill of Quantities shall contain items for the construction, installation, testing, and commissioning work to be done by the Contractor.
	45.2	The Bill of Quantities is used to calculate the Contract Price. The Contractor shall be paid for the quantity of the work done at the rate in the Bill of Quantities for each item.
46. Changes in the Quantities	46.1	If the final quantity of the work done differs from the quantity in the Bill of Quantities for the particular item by more than 25 percent, provided the change exceeds 1 percent of the Initial Contract Price, the Project Manager shall adjust the rate to allow for the change.
	46.2	The Project Manager shall not adjust rates from changes in quantities if thereby the Initial Contract Price is exceeded by more than 15 percent, except with the prior approval of the Employer.

	46.3	If requested by the Project Manager, the Contractor shall provide the Project Manager with a detailed cost breakdown of any rate in the Bill of Quantities.
47. Variations	47.1	All Variations shall be included in updated Work Programs produced by the Contractor.
48. Payments for Variations	48.1	The Contractor shall provide the Project Manager with a quotation for carrying out the Variation when requested to do so by the Project Manager. The Project Manager shall assess the quotation, which shall be given within seven days of the request or within any longer period stated by the Project Manager and before the Variation is ordered.
	48.2	If the work in the Variation corresponds with an item description in the Bill of Quantities and if, in the opinion of the Project Manager, the quantity of work is not above the limit stated in GCC 44.1 [Uncorrected Defects] or the timing of its execution do not cause the cost per unit of quantity to change, the rate in the Bill of Quantities shall be used to calculate the value of the Variation. If the cost per unit of quantity changes, or if the nature or timing of the work in the Variation does not correspond with items in the Bill of Quantities, the quotation by the Contractor shall be in the form of new rates for the relevant items of Work.
	48.3	If the Contractor's quotation is unreasonable, the Project Manager may order the Variation and make a change to the Contract Price, which shall be based on the Project

		Manager's own forecast of the effects of the Variation on the Contractor's costs.
	48.4	If the Project Manager decides that the urgency of varying the work would prevent a quotation being given and considered without delaying the work, no quotation shall be given and the Variation shall be treated as a Compensation Event.
	48.5	The Contractor shall not be entitled to additional payment for costs that could have been avoided by giving early warning notice.
49. Cash Flow Forecasts	49.1	When the Works Program is updated, the Contractor shall provide the Project Manager with an updated cash flow forecast. The cash flow forecast shall include different currencies, as defined in the Contract, converted as necessary using the Contract exchange rates.
50. Payment Certificates	50.1	The Contractor shall submit to the Project Manager monthly statements of the estimated value of the work executed less the cumulative amount certified previously.
	50.2	The Project Manager shall check the Contractor's monthly statement and certify the amount to be paid to the Contractor within twenty eight (28) days from the receipt of the statement.

	50.3	The value of work executed shall be determined by the Project Manager.
	50.4	The value of work executed shall comprise the value of the quantities of the items in the Bill of Quantities completed.
	50.5	The value of work executed shall include the valuation of Variations, Compensation Events and Variation of Price.
	50.6	The Project Manager may exclude any item certified in a previous certificate or reduce the proportion of any item previously certified in any certificate in the light of later information.
	50.7	The Project Manager shall not be bound to certify any payment, if the net amount, after all retentions and deductions would be less than minimum amount of Interim Payment Certificate stated in the SCC.

51. Payments	51.1	Payments shall be adjusted for deductions for advance payments and retention. The Employer shall pay the Contractor the amounts certified by the Project Manager within 28 days of the date of each certificate. If the Employer makes a late payment the Contractor shall be paid interest on the late payment in the next payment. Interest shall be calculated from the date by which the payment should have been made up to the date when the late payment is made at the prevailing rate of interest issued by the Bank of Tanzania on the date of Contract signature for each of the currencies in which payments are made.
	51.2	If an amount certified is increased in a later certificate or as a result of an award by the Adjudicator or an Arbitrator, the Contractor shall be paid interest upon the delayed payment as set out in this clause. Interest shall be calculated from the date upon which the increased amount would have been certified in the absence of dispute.
	51.3	Unless otherwise stated, all payments and deductions will be paid or charged in the proportions of currencies comprising the Contract Price.
	51.4	Items of the Works for which no rate or price has been entered in will not be paid for by the Employer and shall be deemed covered by other rates and prices in the Contract.

52. Currencies	52.1	The currency of payment shall be stated in the SCC.
		Where payments are to be made in currencies other than the Tanzania Shillings, the exchange rates to be used for calculating such amounts shall be the Bank of Tanzania exchange rate prevailing on the date of contract signature.
53. Compensation Events	53.1	<p>The following shall be Compensation Events:</p> <ul style="list-style-type: none"> (a) The Employer does not give access to a part of the Site by the Site Possession Date stated in the Special Conditions of Contract. (b) The Employer modifies the Schedule of Other Contractors in a way that affects the work of the Contractor under the Contract. (c) The Project Manager orders a delay or does not issue Drawings, Specifications, or instructions required for execution of the Works on time. (d) The Project Manager instructs the Contractor to uncover or to carry out additional tests upon work, which is then found to have no Defects. (e) The Project Manager unreasonably does not approve a subcontract to be let. (f) Ground conditions are substantially more adverse than could reasonably have been assumed before

		<p>issuance of the Letter of Acceptance from the information issued to Tenderers (including the Site Investigation Reports), from information available publicly and from a visual inspection of the Site.</p> <p>(g) The Project Manager gives an instruction for dealing with an unforeseen condition, caused by the Employer, or additional work required for safety or other reasons.</p> <p>(h) Other contractors, public authorities, utilities, or the Employer does not work within the dates and other constraints stated in the Contract, and they cause delay or extra cost to the Contractor.</p> <p>(i) The advance payment is delayed.</p> <p>(j) The effects on the Contractor of any of the Employer's Risks.</p> <p>(k) The Project Manager unreasonably delays issuing a Certificate of Completion.</p> <p>(l) Other Compensation Events described in the Contract or determined by the Project Manager shall apply.</p>
	53.2	<p>If a Compensation Event would cause additional cost or would prevent the work being completed before the Intended Completion Date, the Contract Price shall be increased and/or the Intended Completion Date shall be extended. The Project Manager shall, upon consultation with Employer, decide whether and by, how much the Contract Price shall be increased and whether and by how much the Intended Completion Date shall be</p>

		extended.
	53.3	As soon as information demonstrating the effect of each Compensation Event upon the Contractor's forecast cost has been provided by the Contractor, it shall be assessed by the Project Manager, if agreed by the Employer, the Contract Price may be adjusted accordingly. If the Contractor's forecast is deemed unreasonable, the Project Manager in consultation with Employer shall adjust the Contract Price based on the Project Manager's own forecast.
	53.4	The Contractor shall not be entitled to compensation to the extent that the Employer's interests are adversely affected by the Contractor's not having given early warning notice or not having cooperated with the Project Manager.

54. Effect of Changes in Tax Laws	54.1	The Project Manager shall adjust the Contract Price if taxes, duties, and other levies are changed between the date 28 days before the submission of Tenders for the Contract and the date of the last Completion certificate.
	54.2	The adjustment shall be the change in the amount of tax payable by the Contractor, provided such changes are not already reflected in the Contract Price or are a result of GCC 55 [Price Adjustment].
	54.3	In the event that the Laws Governing Taxes, Duties and other levies have changed between the signature date and the last completion certificate thereby affecting the Contract Price, the Employer and the Contractor, shall mutually adjust the contract price accordingly.
55. Price Adjustment	55.1	The amounts payable to the Contractor, pursuant to GCC 50.1 [Payment Certificate], may be adjusted in respect of the rise or fall in the cost of labour, Contractor's Equipment, Plant, materials, and other inputs to the Works, by applying to such amounts the formulae prescribed in this clause.
	55.2	To the extent that full compensation for any rise in costs to the Contractor is not covered by the provisions of this or other clauses in the Contract, the unit rates and prices included in the Contract shall be deemed to include amounts to cover the contingency of such other rise of costs.
	55.3	The adjustment to be applied to amount payable to the Contractor as certified in Payment Certificates shall be

determined by a formulae for each of the currencies in which the Contract Price is payable. No adjustment is to be applied to work valued on the basis of Cost or current prices. The formulae shall be as follows;

$$P_n = a + b \frac{L_n - L_o}{L_o} + c \frac{M_n - M_o}{M_o} + d \frac{E_n - E_o}{E_o} + \text{etc.}$$

where;

P_n is a price adjustment factor to be applied to the amount in each specific currency for the payment of the work carried out in the subject month, where such variations and daywork are not otherwise subject to adjustment;

a is a constant, specified in the **Appendix to Tender**, representing the nonadjustable portion in contractual payments;

$b, c, d, \text{etc.}$, are weightings or coefficients representing the estimated proportion of each cost element (labor, materials, equipment usage, etc.) in the Works or sections thereof, net of Provisional Sums, as specified in the **Appendix to Tender**; the sum of $a, b, c, d, \text{etc.}$, shall be one;

$L_n, M_n, E_n, \text{etc.}$, are the current cost indices or reference prices of the cost elements in the specific currency of origin for month "n," determined pursuant to GCC 55.5, applicable to each cost element; and

$L_o, M_o, E_o, \text{etc.}$, are the base cost indices or reference prices corresponding to the above cost elements at the

		<p>date specified in GCC 55.5</p> <p>The value of net work done, certified by the Project Manager, in any monthly Interim or Final Certificate as payable by the Employer to the Contractor before deduction of any retention money shall be increased or decreased by an amount of 'F'.</p> $F = PnxPc$ <p>where;</p> <p>The effective value Pc of work done which is to be subjected to increase or decrease shall be the difference between:</p> <p>(i) the amount which, in the opinion of the Project Manager, is due to the Contractor under GCC 44 [Uncorrected Defects] (before deduction of retention money and before deducting sums previously paid on account) less:</p> <ul style="list-style-type: none"> • any amount for payment or repayment of any advance payment; • any amount for materials on site (if any); • any amounts for nominated sub-contractors (if any) • any amounts for any other items based on actual cost or current prices; or • any sums for increase or decreases in the Contract Price paid under GCC 55.3 <p>and</p> <p>(ii) the amount calculated in accordance with (i) above of GCC 55.3 and included in the last preceding statement.</p>
	55.4	<p>The sources of indices shall be those listed in the Appendix to Tender, as approved by the Project Manager. Indices shall be appropriate for their purpose and shall relate to the Contractor's proposed source of</p>

		supply of inputs on the basis of which his Contract Price and expected foreign currency requirements shall have been computed. As the proposed basis for price adjustment, the Contractor shall have submitted with his Tender the tabulation of Weightings and Source of Indices in the Appendix to Tender , which shall be subject to approval by the Project Manager.
	55.5	The base cost indices or prices shall be those prevailing on the day 28 days prior to the latest date for submission of Tenders. Current indices or prices shall be those prevailing on the day 28 days prior to the last day of the period to which a particular Interim Payment Certificate is related. If at any time the current indices are not available, provisional indices as determined by the Project Manager will be used, subject to subsequent correction of the amounts paid to the Contractor when the current indices become available
	55.6	If the Contractor fails to complete the Works within the time for completion prescribed under GCC 20 [Commencement and Completion of Works] adjustment of prices thereafter until the date of completion of the Works shall be made using either the indices or prices relating to the prescribed time for completion, or the current indices or prices, whichever is more favorable to the Employer, provided that if an extension of time is granted pursuant to GCC 35 [Extension of the Intended Completion Date], the above provision shall apply only to adjustments made after the expiry of such extension of time.
	55.7	The weightings for each of the factors of cost given in the Appendix to Tender shall be adjusted if, in the opinion of

		the Project Manager, they have been rendered unreasonable, unbalanced, or inapplicable as a result of varied or additional work already executed or instructed under GCC 48 [Payment for Variations] or for any other reason.
56. Retention	56.1	The Employer shall retain from each payment due to the Contractor the proportion stated in the Special Conditions of Contract . The total amount of retention shall not exceed the amount specified in the Special Conditions of Contract
	56.2	On completion of the whole of the Works, half the total amount retained shall be repaid to the Contractor and the other half when the Defects Liability Period has passed and the Project Manager has certified that all Defects notified by the Project Manager to the Contractor before the end of this period have been corrected.
	56.3	On completion of the whole Works, the Contractor may substitute retention money with an 'on demand" or unconditional Bank guarantee.

57. Liquidated Damages	57.1	The Contractor shall pay liquidated damages to the Employer at the rate per day stated in the SCC for each day that the Completion Date is later than the Intended Completion Date. The total amount of liquidated damages shall not exceed the maximum amount of performance security stated in the SCC. The Employer may deduct liquidated damages from payments due to the Contractor. Payment of liquidated damages shall not affect the Contractor's liabilities.
	57.2	Where the Project Manager, after assessment of work progress, upon satisfaction that the Contractor will not complete the works within the contract period, may issue a notice to the Contractor requiring the payment of liquidated damages pursuant to GCC 57.1
	57.3	If the Intended Completion Date is extended after liquidated damages have been paid, the Project Manager shall correct any overpayment of liquidated damages by the Contractor by adjusting the next payment certificate. The Contractor shall be paid interest on the overpayment, calculated from the date of payment to the date of repayment, at the rates specified in GCC 51.1 [Payments]

58. Bonus	58.1	If stated in the Special Conditions of Contract the Contractor shall be paid a Bonus calculated at the rate per calendar day for each day (less any days for which the Contractor is paid for acceleration) that the Completion is earlier than the Intended Completion Date. The Project Manager shall certify that the Works are complete, although they may not be due to be complete.
59. Advance Payment	59.1	If stated in the SCC the Employer shall make advance payment to the Contractor of the amounts stated in the SCC by the date stated in the SCC , against provision by the Contractor of an Unconditional Bank Guarantee in a form and by a bank acceptable to the Employer in amounts and currencies equal to the advance payment. The Guarantee shall remain effective until the advance payment has been repaid, but the amount of the Guarantee shall be progressively reduced by the amounts repaid by the Contractor. Interest will not be charged on the advance payment.
	59.2	The Contractor is to use the advance payment only to pay for Equipment, Plant, Materials, and mobilization expenses required specifically for execution of the Contract. The Contractor shall demonstrate that advance payment has been used in this way by supplying copies of invoices or other documents to the Project Manager.
	59.3	The advance payment shall be repaid by deducting proportionate amounts from payments otherwise due to the Contractor, as specified in the SCC following the schedule of completed percentages of the Works on a payment basis. No account shall be taken of the advance payment or its repayment in assessing valuations of

		work done, Variations, price adjustments, Compensation Events, Bonuses, or Liquidated Damages.
60. Performance Securities	60.1	The Performance Security shall be provided to the Employer no later than the date specified in the Letter of Acceptance and shall be issued in an amount and form and by a bank or surety acceptable to the Employer, and denominated in the types and proportions of the currencies in which the Contract Price is payable as specified in the TDS and SCC and in accordance with the conditions of contract.
	60.2	The Performance Security shall be valid until a date 28 days from the date of issue of the Certificate of Completion in the case of a Bank Guarantee, and until one year from the date of issue of the Completion Certificate in the case of a Performance Bond
	60.3	Where circumstances necessitate the amendment of the contract after signature, and such amendment is effected, the Employer shall require the Contractor to provide additional Performance Security to cover any cumulative increase of more than ten percent of the Initial Contract Price.

61. Day-works	61.1	If applicable, the Day-works rates in the Contractor's Tender shall be used for small additional amounts of work only when the Project Manager has given written instructions in advance for additional work to be paid for in that way.
	61.2	All work to be paid for as Day-works shall be recorded by the Contractor on forms approved by the Project Manager. Each completed form shall be verified and signed by the Project Manager within two days of the work being done.
	61.3	The Contractor shall be paid for Day-works subject to obtaining signed Day-works forms.
62. Cost of Repairs	62.1	Loss or damage to the Works or Materials to be incorporated in the Works between the Commencement Date and the end of the Defects Correction periods shall be remedied by the Contractor at the Contractor's cost if the loss or damage arises from the Contractor's acts or omissions.
		E. Discharge of the Contract

63. Completion Certificate	63.1	The Contractor shall request the Project Manager to issue a certificate of Completion of the Works, and the Project Manager will so issue upon satisfaction that the work is completed.
64. Site Hand Over	64.1	When the Certificate of Completion is issued by the Project Manager, the Contractor shall handover the site and the works to the Employer within time specified in the SCC
65. Final Account	65.1	Upon the expiry of the defect liability period, the Contractor shall supply the Project Manager with a detailed account of the total amount that the Contractor considers payable under the Contract. The Project Manager shall, within fifty-six (56) days, verify the account and, upon satisfaction, certify any final payment due to the Contractor and thereafter issue a defect liability certificate.
	65.2	In the event the Project Manager is not satisfied with the Account submitted by the Contractor pursuant to sub-GCC 65.1, shall within 56 days issue a schedule of correction. If the final account remains unsatisfactory after it has been re-submitted, the Project Manager shall, upon consultation with the Employer, decide on the amount payable to the Contractor and issue a payment certificate.
66. Operating and	66.1	The Contractor shall supply to the Employer the "as

Maintenance Manuals		built" Drawings and/or operating and maintenance manuals and any other related documents by the handover period stipulated pursuant to GCC 64.1 [Site Hand Over].
	66.2	If the Contractor does not supply the Drawings and/or manuals stated in GCC 66.1 by the dates specified pursuant to GCC 64.1 [Site Hand Over] or they do not receive the Project Manager's approval, the Project Manager shall withhold the amount stated in the Special Conditions of Contract from payments due to the Contractor.
67. Termination	67.1	The Employer or the Contractor may terminate the Contract if the other party causes a fundamental breach of the Contract.
	67.2	Fundamental breaches of Contract shall include, but shall not be limited to, the following: <ul style="list-style-type: none"> a) the Contractor stops work for 28 days when no stoppage of work is shown on the current Works Program and the stoppage has not been authorized by the Project Manager; b) the Project Manager instructs the Contractor in writing to delay the Works progress , and the instruction is not withdrawn in writing within 28 days; c) contractor's failure to submit performance security within the time stipulated in the SCC; d) the Employer or the Contractor is declared bankrupt or goes into liquidation other than for a reconstruction or amalgamation;

	<p>e) a payment certified by the Project Manager is not paid by the Employer to the Contractor after 84 days from the date of the Project Manager's certificate;</p> <p>f) Failure of the Contractor to correct the defect after lapse of time specified in the notice to correct defects issued by the Project Manager.;</p> <p>g) where the Contractor fails to furnish and maintain the required Site Security pursuant to GCC 33.1 [Security of the Site];</p> <p>h) The Contractor has delayed the completion of the Works by the number of days for which the maximum amount of liquidated damages can be paid, as defined in the SCC; and</p> <p>i) if the Employer determines, based on the reasonable evidence, that the Contractor has engaged in corrupt, coercive, collusive, obstructive or fraudulent practices, in competing for or in executing the Contract.</p> <p style="padding-left: 40px;">For the purpose of this paragraph:</p> <p style="padding-left: 80px;">"corrupt practice means the offering, giving receiving or soliciting of anything of value to influence the action of a public officer in the procurement process or contract execution;</p> <p style="padding-left: 80px;">"coercive practice" means impairing or harming, or threatening to impair or harm directly or indirectly, any party or the property of the party for the purpose of influencing improperly the action or that party in connection with public procurement or in furtherance of corrupt practice or fraudulent practice;</p> <p style="padding-left: 80px;">collusive practices" means impairing or harming, or threatening to impair or harm</p>
--	---

		<p>directly or indirectly, any part or the property of the Party for the purpose of influencing improperly the action or a part or in connection with public procurement or government contracting or in furtherance of a corrupt practice or a Fraudulent Practice</p> <p>"fraudulent practice" means a misrepresentation of facts in order to influence a procurement process or the execution of a contract to the detriment of the Employer and includes collusive practices among tenderers, prior to or after submission designed to establish tender prices at artificial non-competitive levels and to deprive the Employer of the benefits of free and open competition;</p> <p>"obstructive practice" means acts intended to materially impede access to required information in exercising a duty under this contract;</p>
	67.3	When either party to the Contract gives notice of a fundamental breach of Contract to the other party for a cause other than those listed under GCC 67.2 above, the Project Manager shall decide whether the said breach is fundamental or not.
	67.4	Notwithstanding the above, the Employer may terminate the Contract for convenience.
	67.5	If the Contract is terminated, the Contractor shall stop work immediately, make the Site safe and secure, and

		leave the Site as soon as reasonably possible.
68. Payment upon Termination of Contract	68.1	If the Contract is terminated because of a fundamental breach by the Contractor, the Project Manager shall issue a certificate for the value of the work done and Materials ordered less advance payments received up to the date of the issue of the certificate and less the percentage to apply to the value of the work not completed. Additional Liquidated Damages shall not apply. If the total amount due to the Employer exceeds any payment due to the Contractor, the difference shall be a debt payable to the Employer.
	68.2	If the Contract is terminated for the Employer's convenience or because of a fundamental breach of Contract by the Employer, the Project Manager shall issue a certificate for the value of the work done, Materials ordered, the reasonable cost of removal of Equipment, repatriation of the Contractor's personnel employed solely on the Works, and the Contractor's costs of protecting and securing the Works, and less advance payments received up to the date of the certificate.

69. Property	69.1	All Materials on the Site, Plant, Equipment, Temporary Works, and Works shall be deemed to be the property of the Employer if the contract is terminated for fundamental breach by the Contractor,
70. Suspension of Financing	70.1	<p>In the event that the source of financing is suspended to the Employer, from which part of the payments to the Contractor are being made:</p> <p>(a) The Employer shall notify the Contractor of such suspension within Seven (7) days of having received the financing agency's suspension notice.</p> <p>(b) After the Notice has been issued and within fourteen (14) days, the Parties shall mutually agree on the future events of the Contract</p>
71. Force Majeure	71.1	Neither Party shall have any liability or be deemed to be in breach of the Contract for any delay or other failure in performance of its obligations under the Contract, if such delay or failure is a result of an event of Force Majeure.
	71.2	For purpose of this clause, "Force Majeure" means an event which is beyond the reasonable control of a Party, is not foreseeable, is unavoidable, and its origin is not due to negligence or lack of care on the part of a Party, and which makes a Party's performance of its obligations hereunder impossible or so impractical as reasonably to be considered impossible in the circumstances, and includes, but is not limited to, war, riots, civil disorder, earthquake, fire, explosion, storm, flood, epidemics, or other adverse weather conditions, strikes, lockouts or other industrial action (except where such strikes, lockouts or other industrial action are within the power

		of the Party invoking Force Majeure to prevent
--	--	--

	71.3	If a Party (hereinafter referred to as "the Affected Party") is or will be prevented from performing its substantial obligation under the contract by Force Majeure, it shall give a Notice to the other Party giving full particulars of the event and circumstance of Force Majeure and the reasons for the event of Force Majeure preventing the Affected Party from, or delay the Affected Party from performing its obligations under the Contract. The Notice shall be given within fourteen days after the Affected Party becomes aware, or should have become aware, of the relevant event or circumstances constituting Force Majeure.
	71.4	The Affected Party shall use reasonable efforts to mitigate the effects of the event of Force Majeure and shall endeavour to minimise any delay in the performance of the contract as a result of Force Majeure.
	71.5	The Affected Party shall give Notice to the other Party when it ceases to be affected by the Force Majeure.
	71.6	Upon completion of the event of Force Majeure and issuance Notice pursuant to GCC 71.4, the Affected Party must, as soon as reasonably practicable recommends the performance of its obligations under the contract. Where the Affected Party is the Contractor, the Contractor must provide a revised Work Program rescheduling the Works to minimise the effect of the prevention or delay caused by the event of Force Majeure.
72. Release from Performance	72.1	In the event the Affected Party have used all reasonable efforts to mitigate the effect of the event of force Majeure and minimize any delay in the performance of the contract as result of force Majeure, but the effect of force Majeure still subsist, the Project Manager shall certify that the Contract has been frustrated.

LETTER OF AWARD

THE UNITED REPUBLIC OF TANZANIA
MINISTRY OF HEALTH

Telegrams: "AFYA", DODOMA
Telephone: +255 026 2323267
Email: Ps@afya.go.tz.
(All letters should be addressed to
The Permanent Secretary)



Government City- Mtumba
Afya Street
P. O. Box 743
40478 DODOMA

Ref. No.CAB 209/549/02/143

25th February, 2022

M/s SOFTNET TECHNOLOGIES Ltd,
P.O. BOX 31918
DAR ES SALAAM,

**RE: NOTIFICATION OF CONTRACT AWARD FOR TENDER NO: TENDER
NO:ME/007/2021-2022/W/23 FOR PROPOSED SUPPLY, INSTALLATION
AND COMMISSIONING OF ICT AND SECURITY AT KATAVI (RRH)**

Reference is made to the above heading.

2. Please be informed that, your Tender No: **ME/007/2021-2022/HQ/W/23** submitted was approved by Ministerial Tender Board held on 21st February 2022.
3. The contract is hereby accepted by the Ministry of Health Community Development, Gender, Elderly and Children at a Contract sum of Tanzania Shillings **Nine Hundred Forty-Eight Million Seven Hundred Fifty-four Thousand Nine Hundred Fifty-Seven Seventy-Nine Cents Only (948,754,957.79) VAT Inclusive** VAT inclusive
4. Thank you for your cooperation.

A handwritten signature in black ink, appearing to read 'Abel N. Makubi'.

Prof Abel N. Makubi
PERMANENT SECRETARY (HEALTH)

tm

Copy: Chief Executive Officer
Public Procurement Regulatory Authority
P. O. Box 2865
Dodoma

Copy : The Controller and Auditor General
P. O. Box 950
Dodoma

Copy : Attorney General
Attorney General Chambers
Ministry of Justice and Constitutional
Affairs
P. O. Box 630
Dodoma.

Copy : Director
Technical Audit Unit
Ministry of Finance
P. O. Box 2802
Dodoma

Copy : Internal Auditor General
Ministry of Finance and Planning
P. O. Box 2802
Dodoma

Copy : Regional Manager,
Tanzania Revenue Authority,
P.O.Box 679
Dodoma

4m

LETTER OF ACCEPTANCE

ym

Ref: SNT/L/059/2022

02nd March, 2022

Permanent Secretary
Ministry of Health
P.O. BOX 743
Dodoma, Tanzania

RE: TENDER NO: ME/007/2021-2022/HQ/W/23 FOR PROPOSED SUPPLY, INSTALLATION AND COMMISSIONING OF ICT AND SECURITY AT KATAVI (RRH)

SUB: ACCEPTANCE OF OFFER AND AWARD OF CONTRACT

With reference to your letter dated 25th February, 2022 with reference no. **CAB 209/549/02/143**

Softnet Technologies Limited accept the award of contract for **TENDER NO: ME/007/2021-2022/HQ/W/23 FOR PROPOSED SUPPLY, INSTALLATION AND COMMISSIONING OF ICT AND SECURITY AT KATAVI (RRH)**, at contract price of **TZS. 948,754,957.79, (Tanzania Shillings Nine Hundred Forty Eight Million Seven Hundred Fifty Four Thousand Nine Hundred Fifty Seven and Seventy Nine Cents Only) VAT Inclusive.**

We appreciate Tender Board for approving and awarding Softnet Technologies Limited this contract. We look forward to work with you and make systems to operate to its optimal condition.

Your Sincerely

SOFTNET TECHNOLOGIES LIMITED

Yours Sincerely,



Yusuph Mwakimwagile
HOD - ICT Facilities

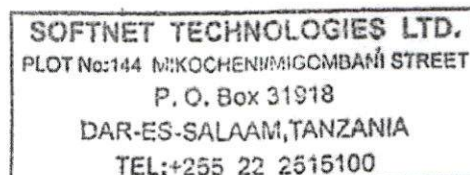

NEGOTIATION MINUTES

ym

THE UNITED REPUBLIC OF TANZANIA

MINISTRY OF HEALTH



MINUTES OF NEGOTIATIONS

FOR TENDER No: ME/007/2021/2022/HQ/C/23

FOR

**PROPOSED SUPPLY, INSTALLATION AND
COMMISSIONING OF ICT AND SECURITY INSTALLATION
WORKS FOR THE COMPLETION CONSTRUCTION OF
KATAVI RRH – OPD, DIAGNOSTIC CENTRE AND
MATERNITY WINGS AT MPANDA MUNICIPALITY, KATAVI
REGION IN TANZANIA.**

08th FEBRUARY, 2022

NU

MM

**PARTIES: MINISTRY OF HEALTH ("CLIENT") AND
M/s SOFTNET TECHNOLOGIES LTD ("CONTRACTOR")**

VENUE: NHIF BUILDING, 6TH FLOOR – PMU OFFICE

DATE: TUESDAY, 08TH FEBRUARY, 2022

TIME: 13:10 HOURS.

PARTICIPANTS

MINISTRY OF HEALTH - CLIENT

- | | | |
|------|--------------------|-------------|
| i. | Eng. Ntele Massawe | Chairperson |
| ii. | Mr. John Ezekiel | Member |
| iii. | Mr. Jelari Gula | Member |
| iv. | Ms Norah Mkonyi | Member |
| v. | Mr. Joshua Anthony | Secretary |

CONTRACTOR PARTICIPANTS



M/S SOFTNET TECHNOLOGIES LTD

- | | | |
|-----|-------------------------|-----------------------------------|
| i. | Mr. Yusuph Mwakimwagile | Head of ICT facilities Department |
| ii. | Mr. Mesha Olav | System Integrator |

1. INTRODUCTION

The negotiation meeting was held following issuance of letter of intent with Ref: No. CAB/92/209/01.D/ dated 5th February, 2022, with an intention to award Tender No ME/007/2021/2022/HQ/C/23 to bidder M/s. SOFTNET TECHNOLOGIES. LTD, P.O BOX 31918, DAR ES SALAAM – CONTRACTOR.

2. Proposed Agenda

1. Opening of the meeting
 2. Approval of proposed agenda
 3. Discussion on contract price
 4. Discussion on payment mode
 5. Discussion on time of contract
 6. Discussion on other related contractual matters
 7. Any other business
- 
- 

8. Closing of the meeting

3. OPENING OF THE MEETING

The Chairperson opened the meeting at 13:10hrs local time by welcoming the participants to the meeting and invited them to introduce themselves as well as to sign the attendance form.

The Chairman informed the participants that the purpose of the meeting is the negotiation between the bidder with the Employer in order to clarify or provide details on raised issues towards an intention to award the contract to the contractor upon successful outcome from the negotiation. He further mentioned the importance of the project to MOH and that the speedy implementation will be highly appreciated.

4. APPROVAL OF PROPOSED AGENDA

The Chairperson read out the Agenda to be followed. The eight (8) proposed agenda were agreed by the members and the Chair Person endorsed and proceeded with the meeting following the agreed agenda.

4.1. CONTRACT PRICE

- i. The contractor agreed to provide a discount of 2% of corrected contract sum of Tshs 800,029,477.86 before 18% VAT and contingency. The discount is Tshs 16,000,589.56.
- ii. The corrected contract sum before VAT and contingency discounted from Tshs 800,029,477.86 to Tshs 784,028,888.30
- iii. The corrected contract sum before VAT and with contingency is Tshs 804,029,625.25.
- iv. The revised contact sum will be Tshs 948,754,957.79 inclusive of 18% VAT.

4.2. Payment Mode

- i. The contractor request the advance payment as stipulated in the special condition of 15% of contract sum and this will be paid upon submission of Unconditional Bank Guarantee.
- ii. It was agreed that other payments to be paid in interim basis as per the conditions of contract.



4.3. Time of Contract.

It was agreed the contract period of 7 months as stipulated in the tender documents, however the contractor ensure the team that they might finish before time indicated.

4.4. Other related Contractual Matters

The following were agreed:

- i. That, the bidder confirm no changes on staffing
- ii. That, no changes on the Terms of Reference
- iii. That, the payment to be effective on time and as stipulated in the special condition.
- iv. That, the builders works, security and storage will be done by Main contractor
- v. That, the contractor supposed to pay all Government taxes as stipulated in the tender document.





5. ANY OTHER BUSINES

No other business.

6. CLOSING THE MEETING

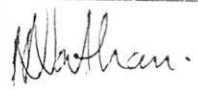
The Chairman closed the meeting at 13:59 Hrs

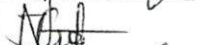
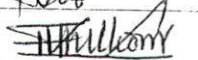
We hereby certify that the above is a true and accurate record of the negotiations:

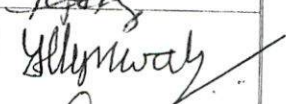
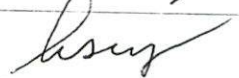



PART 2: RECORD OF ATTENDANCE AT NEGOTIATIONS				
S/N	Name	Position	Firm/Company	Signature
1	Eng. Ntele Massawe	Chairperson	Project Mechanical Consultat	
2	Mr. John Ezekiel	Member	MOH/Katavi RRH	
3	Mr. Jeladi Gula	Member	MOH/Katavi RRH	
4	Mr. Joshua Antony	Secretary	MOH	
5	Ms Norah Mkonyi	Member	MOH	
5	Mr. Yusuph Mwakimwagile	Head of ICT facilities Department	SoftNet Technologies Ltd	
6	Mr. Meshu Olav	System integrator	SoftNet Technologies Ltd	

Ym

ATTENDANCE REGISTER FOR NEGOTIATION MINUTES HELD ON 8TH FEBRUARY 2022

TENDER NAME: PROPOSEDC SUPPLY, INSTALLATION AND COMMISIONING ICT AND SECURITY AT KATAVI RHH HOSPITAL

TENDER NO: ME/007/2021-2022/HQ/W/23

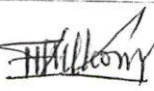





S/N	NAME	DESIGNATION	TEAM MEMBER (POSITION)	ORGANIZATION REPRESENTED	SIGNATURE
1	Eng. Ntebe Massawe	Consultant (Project)	Chairman	Crystal / Mecplan	
2	Norah Mkonji	So	Member	MCH	
3	JOHN EZEICHEL	ICTO	User Representative	KATAVI RHH	
4	MESHA OLAV	Systems Integrator	Soft Member	SOFTNET	
5	MUSUPH MWAKIMWAGILE	HOD ICT FACILITIES	"	SOFTNET	
6	JOSHUA A. NTA BUZA	So (Pnuco)	Secretary	MCH	

7/m

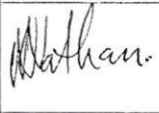
ATTENDENCE REGISTER FOR NEGOTIATION MINUTES HELD ON 8TH FEBRUARY 2022

TENDER NAME: PROPOSEDC SUPPLY, INSTALLATION AND COMMISIONING ICT AND SECURITY AT KATAVI RHH HOSPITAL

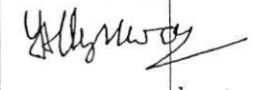
TENDER NO: ME/007/2021-2022/HQ/W/23

S/N	NAME	DESIGNATION	TEAM MEMBER (POSITION)	ORGANIZATION REPRESENTED	SIGNATURE
1	Eng. Ntete Massawe	Consultant (Project)	Chairman	Crystal / Mecplan	
2	Norah Mkonyi	SO	Member	MOH	
3	JOHN EZEKIEL	ICTO	User Representative	KATAVI RHH	
4	MESHA OLAV	Systems Integrator	SOFT Member	SOFTNET	
5	MUSUPH MWAKIMWAGILE	HOD ICT FACILITIES	"	SOFTNET	
6	JOSHUA A. NTA BUZA	SO (PMUO)	Secretary	MOH	

ym

BILL OF QUANTITIES

7m

ICT AND SECURITY SERVICES INSTALLATION

ym

			QTY	UNIT	RATE	TOTAL
					TZS	TZS
<u>PRELIMINARIES</u>						
a		Allow for operational and maintenance manuals (two copies)	2	Set	300,000.00	600,000.00
b		Allow for as built drawings (two copies soft and hard copies) A2 Format	2	Set	250,000.00	500,000.00
c		Allow for mobilization to the site	1	Item	1,400,000.00	1,400,000.00
d		Allow for demobilization from the site	1	Item	1,500,000.00	1,500,000.00
e		Allow for builders works in connection with ICT and Security installations	1	Item	1,000,000.00	1,000,000.00
f		The Contactor to list any item for which he thinks claim should be made				
TOTAL PRELIMINARIES CARRIED TO SUMMARY					TZS	5,000,000.00

Ym

			QTY	UNIT	RATE	TOTAL
					TZS	TZS
<u>STRUCTURED CABLING</u>						
<u>Supply the following as siemon or approved equal:</u>						
<u>Horizontal Subsystem</u>						
a	Double RJ45 information outlets, with faceplate, loaded shutter and Labeling field, this should be c/w mounting box	156	No	37,896.64	5,911,875.84	
b	Data/telephone UTP cat.6, Low Smoke Zero Halogen (LSZH) cable	115	Roll	622,440.00	71,580,600.00	
<u>Administration Subsystem</u>						
c	18U High x 800 mm Wide x 1 m Deep , Wall mounted Data Cabinet complete with smoked lockable glass door, metallic side panels and high-speed heat-extracting fans	6	No	1,801,800.00	10,810,800.00	
d	42U High x 800 mm Wide x 1 m Deep, Floor-Standing Data Cabinet complete with smoked lockable glass door, metallic side panels and high-speed heat-extracting fans	1	No	2,620,800.00	2,620,800.00	
e	48-port RJ45 patch panels, complete with real cable managers (with keyable ports)	8	No	949,941.72	7,599,533.76	
f	Cable and Patch cord management panels	30	No	76,560.12	2,296,803.60	
g	4 pair 1.0 m long RJ45 to RJ45 patch cord, factory-made and tested					

Ym

	(keyed to prevent accidental disconnection)	312	No	13,398.84	4,180,438.08
h	20A, 5-ways switched Power Distribution Unit	7	No	91,000.00	637,000.00
<u>Backbone Subsystem</u>					
i	8-ways Fiber Panel complete with management trays, LC adapters and pigtails	14	No	884,683.80	12,385,573.20
j	8-Core Fiber Cable (50/125 µm Multi-mode) from each patch room to the distribution switch at server room	360	LM	15,724.80	5,660,928.00
k	64-ways Fiber Panel complete with management trays, LC adapters and pigtails	2	No	4,210,085.88	8,420,171.76
l	1.0 m long Fiber Patch Cord, LC connectors (50/125 µm Multi-mode)	21	No	88,681.32	1,862,307.72
<u>Supply and installation the following Cisco Access switches, PoE:</u>					
m	Cisco Catalyst 3560-48PS, 24-ports, PoE, 10/100 Mbps and 4 SFP-based Gigabit Ethernet uplink ports, IP Base (WS-C3560-48PS-S)	14	No	18,370,978.13	257,193,693.75
n	Catalyst 3560 SFP Interconnect Cable, 50cm	14	No	587,500.00	8,225,000.00
o	Gigabit Ethernet SFP, LC connector, SX transceiver for Multi-mode Fiber (GLC-SX-MM)	14	No	969,375.00	13,571,250.00
p	1.5 KVA APC Smart UPS (Rack Mounted)	7	No	1,869,000.00	13,083,000.00

Ym

		with min 8 GB of RAM,min 2.0 TB storage, 17" HD monitor, keyboard,				
		mouse. The CPU should be compatible with IP CCTV system and				
		software complete in all respect	1	No	11,750,000.00	11,750,000.00
d		Supply, installation, testing and commissioning of video Storage with				
		RAID-5 back up device to record images of all cameras at 30 FPS for				
		120 days in 4 CIF/SIF resolution and H.264 compression	1	No	5,000,000.00	5,000,000.00
e		Virtual matrix display controller (CMS Server) for atleast 8 monitors	1	No	2,457,000.00	2,457,000.00
f		12 ways KVM Switch	1	No	8,960,000.00	8,960,000.00
<u>Monitoring Devices</u>						
g		Full HD 50" TFT monitor with mounting brackets and other necessary				
		accessories	2	No	3,264,300.00	6,528,600.00
h		Keyboard and joystick integrated with a small screen for Video				
		Management	1	No	2,808,000.00	2,808,000.00
i		Workstation with already installed management software	1	No	3,450,670.00	3,450,670.00
<u>CCTV CAMERA INSTALLATION</u>						
j		Data/telephone UTP cat.6, Low Smoke Zero Halogen (LSZH) cable	15	Roll	622,440.00	9,336,600.00

Ym

k		24-port RJ45 patch panels, complete with real cable managers				
		(with keyable ports)	4	No	345,339.46	1,381,357.82
l		4 pair 1.0 m long RJ45 to RJ45 patch cord, factory-made and tested				
		(keyed to prevent accidental disconnection)	67	No	13,398.84	897,722.28
m		Cable and Patch cord management panels	4	No	76,560.12	306,240.48
Administration Subsystem						
n		18U High x 800 mm Wide x 1 m Deep, Wall mounted Data Cabinet				
		complete with smoked lockable glass door, 5 ways PDU, metallic side				
		panels and high-speed heat-extracting fans	2	No	1,801,800.00	3,603,600.00
Cisco Access Switches, PoE						
o		Cisco Catalyst 2960, 24 10/100 PoE ports, 2 dual-purpose (T/SFP)				
		Gigabit Ethernet ports (WS-C2960-24PC-L)	3	No	4,112,500.00	12,337,500.00
p		Catalyst 2960S 24 GigE, 2 SFP Gigabit uplink ports (WS-C2960S-24TS-S)	1	No	9,987,500.00	9,987,500.00
TOTAL CCTV INSTALLATION CARRIED TO SUMMARY					TZS	119,850,730.58

Ym

			QTY	UNIT	RATE	TOTAL
					TZS	TZS
<u>IP BASED ACCESS CONTROL SYSTEM</u>						
a	Access control server		1	No	4,312,500.00	4,312,500.00
b	Access control software and its licence		1	No	1,158,300.00	1,158,300.00
c	Main workstation including keyboard and mouse, 2 x 22 inches TFT monitors for the software and graphics		1	No	2,721,250.00	2,721,250.00
d	Ditto but operator workstation comprising of 1x19 inches TFT monitor for security operator		1	No	2,471,250.00	2,471,250.00
e	Door Controllers (IP Controller) controlling atleast 8 readers: Each door having entry and exit reader)		3	No	506,250.00	1,518,750.00
f	Acces control Readers with the capability of reading proximity cards and biometric finger scan		20	No	857,025.00	17,140,500.00
g	Proximity card		50	No	3,125.00	156,250.00
h	12V DC Electro-magnetic lock with monitoring functions		20	No	261,250.00	5,225,000.00
i	Power supply Units for magnetic locks		20	No	168,750.00	3,375,000.00
j	Automatic door closer		10	No	71,250.00	712,500.00
k	8 cores alarm cables		10	Roll	75,000.00	750,000.00

Ym

						TZS	39,541,300.00	
TOTAL IP BASED ACCESS CONTROL SYSTEM CARRIED TO SUMMARY								

				QTY	UNIT	RATE	TOTAL
						TZS	TZS
<u>FIRE DETECTION AND ALARM SYSTEMS</u>							
<u>GROUND AND FIRST FLOOR</u>							
a		2 core of 1.5 sq. mm Pirelli fire cable		70	Roll	604,230.66	42,296,146.38
b		Intelligent smoke detector		207	No	114,610.33	23,724,337.28
c		Intelligent Heat detector		7	No	113,634.18	795,439.23
d		Intelligent Manual call points		25	No	84,177.73	2,104,443.13
e		Adressable sounder		15	No	327,064.33	4,905,964.88
f		Short circuits Isolator		20	No	66,549.78	1,330,995.50
g		XFP Networkable Four loop fire panel Context Plus XP95 protocol Key switch entry, c/w 3A psu, metal enclosure (XFP502/X)		1	No	7,895,594.53	7,895,594.53
h		XFP Upload download software kit (XFP507) - XFP PROGRAMMING SOFTWARE		1	No	647,295.66	647,295.66
TOTAL FIRE DETECTION AND ALARM SYSTEMS CARRIED TO SUMMARY						TZS	83,700,216.56

Ym

			QTY	UNIT	RATE	TOTAL
					TZS	TZS
<u>NURSE CALL SYSTEM</u>						
<u>Supply addressable nurse call system as QUANTEC or approved equal</u>						
a	Quantec Network Controller		1	No	1,360,125.00	1,360,125.00
b	Network splitter		12	No	87,750.00	1,053,000.00
c	Flush bezel for Quantec Network Controller		12	No	117,000.00	1,404,000.00
d	Corridor display with controls		12	No	643,500.00	7,722,000.00
e	Stainless steel addressable overdoor light c/w sounder, double gang		46	No	160,875.00	7,400,250.00
f	Call point button reset c/w remote socket		209	No	172,020.00	35,952,180.00
g	6ft tail call button with right angle plug		393	No	55,575.00	21,840,975.00
h	Ceiling pulls c/w 3m cord with two open - sided triangular		41	No	67,275.00	2,758,275.00
i	Alarm cables		70	Roll	75,000.00	5,250,000.00
TOTAL NURSE CALL SYSTEM ISTALLATION CARRIED TO SUMMARY					TZS	84,740,805.00

Ym

--	--	--	--	--	--	--	--

				QTY	UNIT	RATE	TOTAL
						TZS	TZS
TV NETWORKING							
A	Channel combiner			1	No	2,275,000.00	2,275,000.00
B	Broadband Amplifier			4	No	312,500.00	1,250,000.00
C	FTA Receiver			10	No	187,500.00	1,875,000.00
D	DStv Decoder			2	No	125,000.00	250,000.00
E	UHF/VHF Modulators			12	No	187,500.00	2,250,000.00
F	DStv Dish 90 cm - full installation			1	No	156,250.00	156,250.00
G	Free to Air dish - (FT 8)			1	No	562,500.00	562,500.00
H	LNB C-band single solution			2	No	138,125.00	276,250.00
I	DStv subscription			2	No	173,750.00	347,500.00
J	Wall Outlets c/w mounting boxes			25	No	26,000.00	650,000.00
K	TV coaxial cable (RG 11, 75 Ohms) for trunk cables			3	Roll	958,750.00	2,876,250.00
L	TV coaxial cable (RG 6) for brank cables			3	Roll	812,500.00	2,437,500.00
M	12U TV cabinet complete with all accessories to accommodate TV system components			1	No	475,000.00	475,000.00

Jm

			TOTAL TV NETWORKING SYSTEM INSTALLATION CARRIED TO SUMMARY			TZS	15,681,250.00

<u>PROPOSED CONSTRUCTION OF KATAVI REGIONAL REFERRAL HOSPITAL COMPLEX</u>							
<u>AT</u>							
<u>MPANDA MUNICIPALITY - MARTENITY BLOCK</u>							
<u>ICT AND SECURITY SERVICES INSTALLATION</u>							
<u>GENERAL SUMMARY</u>							
							TOTAL
						Page	
						No.	TZS
a			PRELIMINARIES			Page No. 1	5,000,000.00
b			STRUCTURED CABLING			Page No. 2	451,515,175.71
c			CCTV SYSTEM INSTALLATIONS			Page No. 1	119,850,730.58
d			IP BASED ACCESS CONTROL SYSTEM			Page No. 1	39,541,300.00

lm

e	FIRE DETECTION AND ALARM SYSTEMS	Page No. 1	83,700,216.56
f	NURSE CALL SYSTEM	Page No. 1	84,740,805.00
g	TV NETWORKING	Page No. 1	15,681,250.00
	SUB-TOTAL I		800,029,477.86
h	CONTIGENCY		20,000,736.95
	SUB-TOTAL II		820,030,214.80
i	Add: VAT	18%	967,635,653.47
	TOTAL CONTRACT SUM CARRIED TO FORM OF AGREEMENT (VAT INCLUSIVE)		967,635,653.47

SOFTNET TECHNOLOGIES LTD.
PLOT No:144 MIKOCHEINI/MIGOMBAZI STREET
P. O. Box 31918
DAR-ES-SALAAM, TANZANIA
TEL:+255 22 2515100

Y. M. Mwakilima

Ym

SPECIFICATION

Ym



GIGANET CABINETS AND ENCLOSURE

GIGANET Networking Solutions provides a comprehensive range of cabinets and enclosures that can be used in computer and telecommunication technology industry. GIGANET products include Server racks, free standing racks, Wall mount racks and accessories. Under the GIGANET brand we also manufacture and provide a 25 year warranty and certified training for a complete end to end range of structured cabling infrastructure solutions to support converged applications on both Copper and Fibre.



GIGANET NETWORKING SOLUTIONS LTD

www.giga-net.co.uk

ym

GN-001 NETWORK SERVER CABINET (MESH DOOR)

Structure



Product Information

- Exquisite design with precise craftsmanship.
- Install castor and adjustable feet are available at the same time.
- Optional plinth enables cabinet to stay in a fixed position, meeting requirements of under-base cable entry/ventilation and prevention.
- Front arc mesh door and rear flat mesh door. Adjustable under-base cable entry to meet various requirements.
- Removable side panels, easy to install and maintain
- Flat pack is optional to reduce the shipment cost, easy to assembly.

Offering Accessories 19" Rack Height 42U width 800mm and depth associated accessories 3 fixed shelf, 4 fans 4 castors 4 feet 40 set cage nuts.

Main material: SPCC cold rolled steel **Thickness of Steel:** mounting profile: 2.0mm; others: 1.2mm.

Surface finish: Surface: degreasing, acid pickling, phosphoric, dip-coat primed, powder coat;

Loading capacity: Static loading: 800KG **Degree of protection:** IP20.

STANDARD: Comply with ANSI/EIA RS-310-D, IEC297-2, DIN41494 ;

PART1, DIN41494; PART7, GB/T3047; 2-92STANDARD.

Specifications

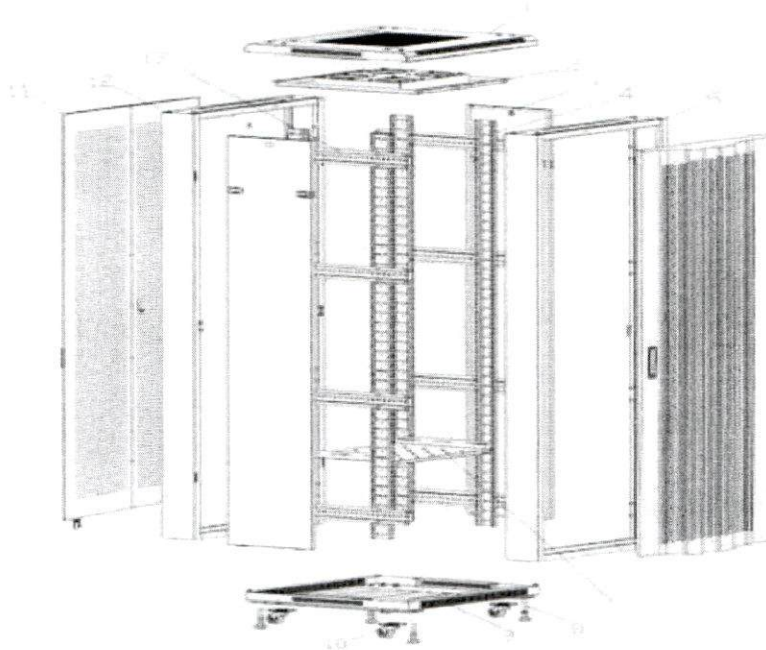

Model No	Capacity (U)	Width (mm)	Depth (mm)	Height (mm)	Packing dimension W*D*H	Volume (CBM)
GN-001-8842	42	800	800	2055	830*830*2070	1.4260
GN-001-81042	42	800	1000	2055	830*1030*2070	1.8700

Definition of Color

Color	
RAL9004	Black

GN-002 NETWORK SERVER CABINET (GLASS DOOR)**Structure****Product Description**

- Elegant look, profound technical, precise dimension, with modern look, add value to your projects.
- Easy to fix concentrated distribution unit into frame.
- Popular front door made by smoky gray color toughened glass.
- Install caster and support feet at the same time.
- Wire path on the top and bottom can be closed, and wire holes dimension can be changed as request.
- Optional bottom seat for stable stand, bottom wiring, bottom cold ventilation and prevent rats.
- Side door and rear/front door can be taken down easily.

Product Information

Exquisite design with precision dimensions and craftsmanship Color: Computer gray or black, vented front/rear doors enable ventilated operation Swiveling wheels and legs can be jointly installed to withstand up to 800kg maximum carrying capacity and 350kg mobile carrying capacity Several lockable wiring holes on top/bottom, size of the large hole at the bottom adjustable Easy-to-disassemble front/rear/left/right doors enable convenient operation from any side of the cabinet Optional installation of base enables the cabinet to stay in a fixed position while meeting requirements of under-base wiring/ventilation Linkage cabinet.

Offering Accessories 19" Rack Height 42U width 800mm and depth associated accessories 3 fixed shelf, 4 fans 4 castors 4 feet 40 set cage nuts.

Main material: SPCC cold rolled steel; **Thickness of Steel:** mounting profile: 2.0mm; others: 1.2mm.
Surface finish: Surface: degreasing, acid pickling, phosphoric, dip-coat primed, powder coat;
Loading capacity: Static loading: 800KG **Degree of protection:** IP20

STANDARD: Comply with ANSI/EIA RS-310-D, IEC297-2, DIN41494 ;

PART1, DIN41494; PART7, GB/T3047; 2-92STANDARD.

Specifications

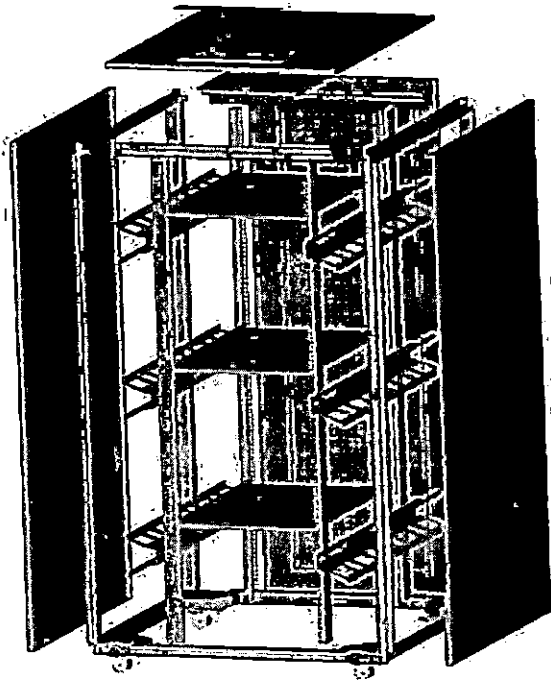

Model No	Capacity (U)	Width (mm)	Depth (mm)	Height (mm)	Packing dimension W*D*H	Volume (CBM)
GN-002-6042	42	600	1000	2055	630*1030*2070	1.3432
GN-002-8042	42	800	1000	2055	830*1030*2070	1.8700

Definition of Color

Color	
RAL9004	Black

jm

GN-002 NETWORK CABINET FREE STANDING 600mm X 600 mm

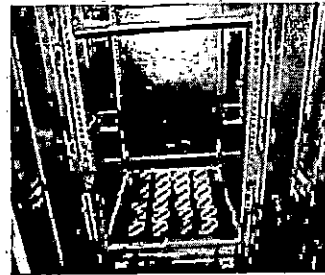
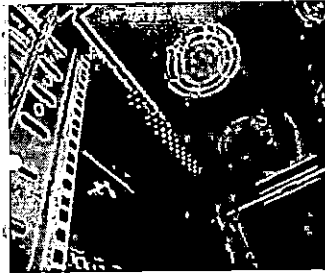
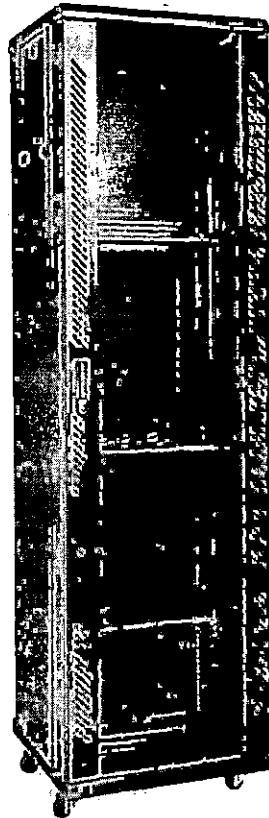

Product Description

- Elegant look, profound technical, precise dimension, with modern look, add value to your projects.
- Easy to fix concentrated distribution unit into frame.
- Popular front door made by smoky gray color toughened glass.
- Install caster and support feet at the same time.
- Wire path on the top and bottom can be closed, and wire holes dimension can be changed as request.
- Optional bottom seat for stable stand, bottom wiring, bottom cold ventilation and prevent rats.
- Side door and rear/front door can be taken down easily.

Product Information

Exquisite design with precision dimensions and craftsmanship Color: Computer gray or black, vented front/rear doors enable ventilated operation Swiveling wheels and legs can be jointly installed to withstand up to 800kg maximum carrying capacity and 350kg mobile carrying capacity Several lockable wiring holes on top/bottom, size of the large hole at the bottom adjustable Easy-to-disassemble front/rear/left/right doors enable convenient operation from any side of the cabinet Optional installation of base enables the cabinet to stay in a fixed position while meeting requirements of under-base wiring/ventilation Linkage cabinet.

Offering Accessories 19" Rack Height assorted sizes depth 600mm width 600mm accessories 3 fixed shelf, 4 fans 4 castors 4 feet 40 set cage nuts.

Main material: SPCC cold rolled steel; **Thickness of Steel:** mounting profile: 2.0mm; others: 1.2mm.

Surface finish: Surface: degreasing, acid pickling, phosphoric, dip-coat primed, powder coat;

Loading capacity: Static loading: 800KG **Degree of protection:** IP20

STANDARD: Comply with ANSI/EIA RS-310-D, IEC297-2, DIN41494 ;

PART1, DIN41494; PART7, GB/T3047; 2-92STANDARD.

Specifications

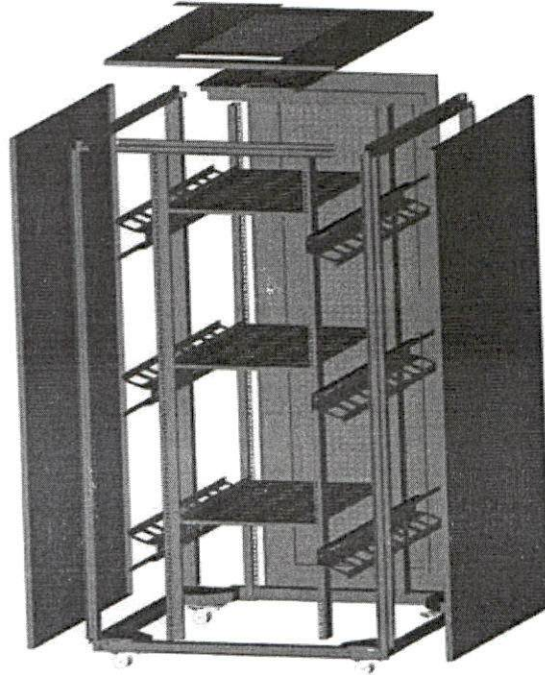

Model No	Capacity (U)	Width (mm)	Depth (mm)	Height (mm)	Packing dimension W*D*H	Volume (CBM)
GN-002-6618	18	600	600	988	630*630*1008	0.3844
GN-002-6622	22	600	600	1166	630*630*1176	0.4459
GN-002-6627	27	600	600	1388	630*630*1403	0.5189
GN-002-6632	32	600	600	1610	630*630*1625	0.6266
GN-002-6642	42	600	600	2055	630*630*2070	0.7881

Definition of Color

Color	
RAL9004	Black

GN-006 WALL MOUNTED NETWORK CABINET

Structure

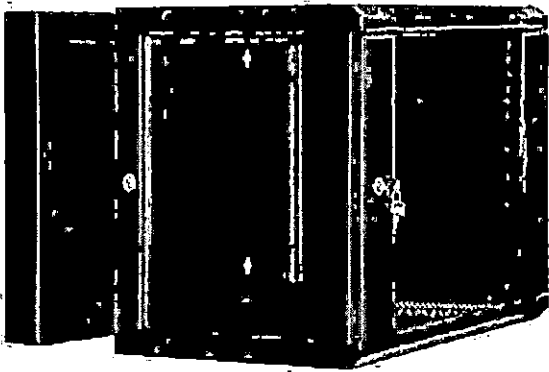

Product Description

- Double section wall mounted cabinet.
- Quick open side door easy to install and maintain.
- Top and bottom wire path.
- Optional caster and support feet for stand installing.
- Optional 120mm axial motor.
- Convenient and quick wall mounting.

Product Information

- Welded frame, reliable structure.
- Double section wall mount cabinet.
- Standing or wall mounting installation.
- Adjustable feet and heavy duty castors are optional
- Easy mount installation .
- 19" standard installation.
- Removable side panels, side locks optional.
- Cable entry on both of top cover and bottom panel.

Offering Accessories:20 sets cage nuts.

Main material: SPCC cold rolled steel; **Thickness of Steel:** mounting profile: 1.5mm; others: 1.2mm.
Surface finish: Surface: degreasing, acid pickling, phosphoric, dip-coat primed, powder coat;
Loading capacity: Static loading 60KG **Degree of protection:** IP20.

Specifications

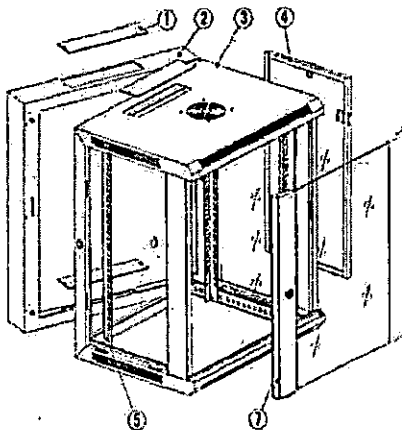

Model No	Capacity (U)	Width (mm)	Depth (mm)	Height (mm)	Packing dimension W*D*H	Volume (CBM)
GN-006-6606	6	600	600	368	630*630*388	0.1937
GN-006-6509	9	600	550	501	630*570*521	0.2923
GN-006-6609	9	600	600	501	630*630*521	0.2923

Definition of Color

Color	
RAL9004	Black

GN-007 WALL MOUNTED NETWORK CABINET

Structures

Product Description

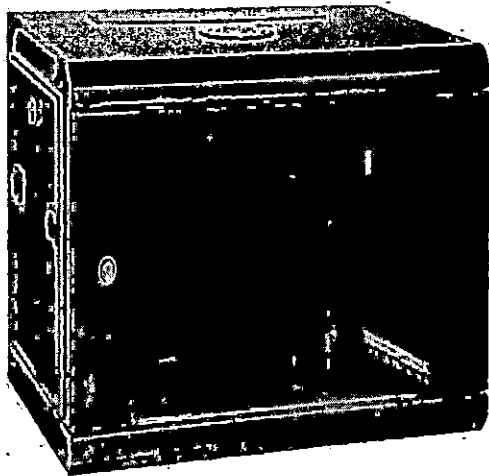

- Wall mount rack.
- Quick open side door easy to install and maintain.
- Top and bottom wire path.
- Optional caster and support feet for stand installing.
- Optional 120mm axial motor.
- Convenient and quick wall mounting.
- Frame structure, max loading 60kgs.

Product Information

- Welded frame, reliable structure.
- Double section wall mount cabinet.
- Standing or wall mounting installation.
- Adjustable feet and heavy duty castors are optional.
- Easy mount installation
- 19" standard installation.
- Removable side panels, side locks optional.
- Cable entry on both of top cover and bottom panel.

Offering Accessories: 20 sets cage nuts.

Main material: SPCC cold rolled steel; **Thickness of Steel:** mounting profile: 1.5mm; others: 1.2mm.
Surface finish: Surface: degreasing, acid pickling, phosphoric, dip-coat primed, powder coat.
Loading capacity: Static loading 60KG **Degree of protection:** IP20

Specifications

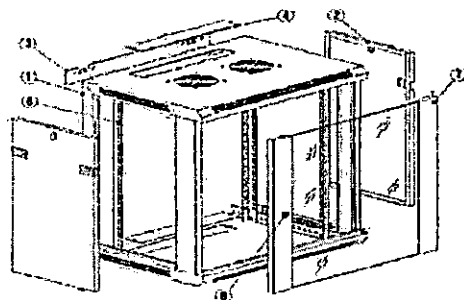

1. THE FRAME
2. SIDE DOOR
3. WALL BRACKET
4. TOP COVER
5. BOTTOM
6. TRAIL
7. FRONT DOOR

Model No	Capacity (U)	Width (mm)	Depth (mm)	Height (mm)	Packing dimension W*D*H	Volume (CBM)
GN-007-6406	6	600	450	368	630*470*388	0.1211
GN-007-6606	6	600	600	368	630*630*388	0.1603
GN-007-6412	12	600	450	635	630*470*655	0.2812
GN-007-6612	12	600	600	635	630*630*655	0.3272
GN-007-6415	15	600	450	769	630*470*789	0.4052
GN-007-6615	15	600	600	769	630*630*721	0.4105
GN-007-6618	18	600	600	901	630*630*721	0.2104

Definition of Color

Color	
RAL9004	Black

Cabinet Accessories

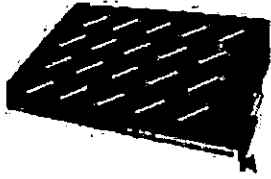

GN-301-3
Front to back fixed support board



GN-301-16
Cooling Fan

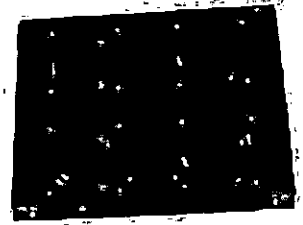

GN-301-07
4 Fan Ventilation Unit

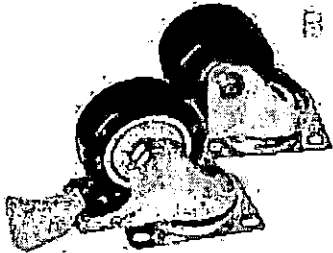

GN-301-22
Castors

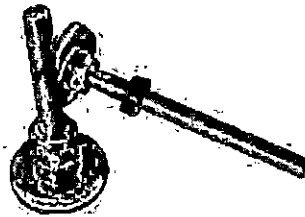

GN-301-23
Feet

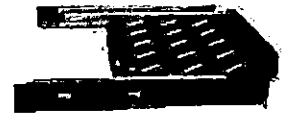

GN-301-5
Keyboard frame

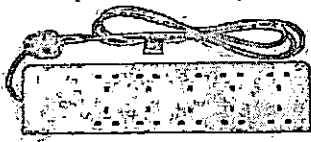

GN-PDU-10
Power Socket



GN-301-14
Vertical Cable Manager

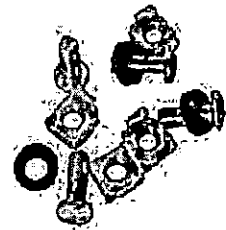

GN-301-24
Screws

NOTES

Lined area for notes, consisting of a large rectangular box with horizontal ruling lines.

jm



GIGANET NETWORKING SOLUTIONS LTD.

**UNIT V17
VECTOR PARK
FOREST ROAD
FELTHAM, TW13 7EJ**

CONTACT US

Telephone: +44 (0) 0208 616 0246

**Sales: sales@giga-net.co.uk
Training Enquiries: training@giga-net.co.uk
Technical Support: support@giga-net.co.uk**

AUTHORIZED DISTRIBUTOR

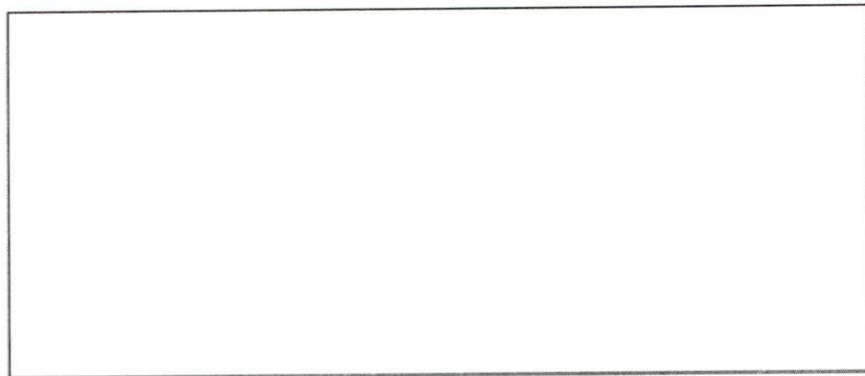

www.giga-net.co.uk

ym

Panasonic

Smart Hybrid PBX

KX-NS500 Approach Book

Evolving systems that
make your dreams come true.

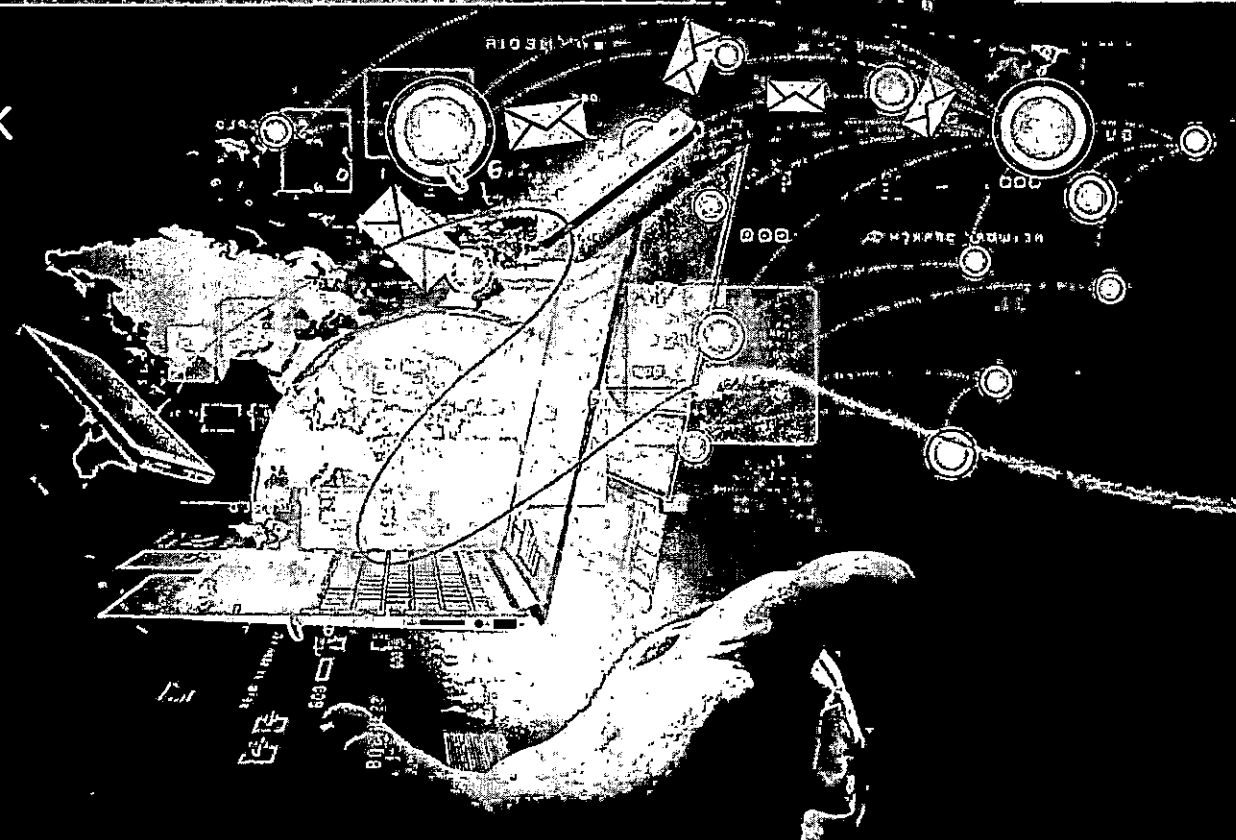

Handwritten mark

Concerns that come hand-in-hand with business

We want to minimize initial costs.

We want a future-proof system.

We want a single unit with multi-functions.

Smart Hybrid System

Flexibility and Scalability

One Package Solution

Smart Hybrid PBX
KX-NS500

Innovate Your Business
With One Package Platform

for

KX-NS500

Superb performance to match your business needs.

Cost saving



Features

- Smart Hybrid System
- Backwards Compatibility

mf

Creating new business styles



Features

- Mobility
- Messaging
- Call Centre

Technology with a future perspective

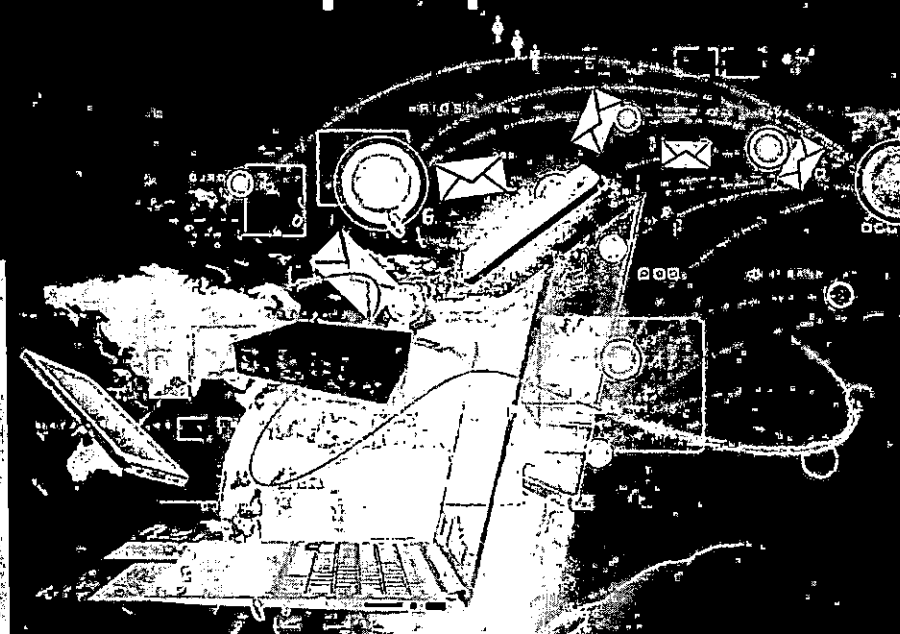

Features

- Unified Communication
- Future Proof

Cost-Saving

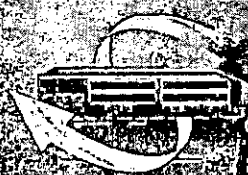

Ideal for any office.

»» The Ideal System Configuration for Your Office

The ability to use your existing phone lines and IP network lets you configure a cost-effective system that meets your needs.

»» Expand as Your Business Grows

This system will suit a variety of company types, and users can expand it to meet their needs.

wf
**Smart
Hybrid
System**



Cost Saving

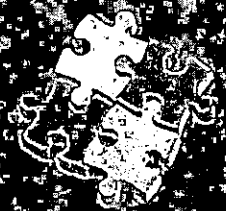

Backwards Compatibility

Installation costs are reduced by the ability to use existing assets.

»» Using Existing Equipment

Continue using existing devices, such as Proprietary Telephones for the Panasonic PBX just as they are.

»» Using Existing Outside Line

There is no need for new contracts, because you can use your existing outside line as is.

TM

Creating new
business styles



Mobility

Shifting Business from the Office to the Field.

»» Panasonic Wireless Systems

Panasonic's wireless phones include compact and tough types, so they can be used just about anywhere in the office. Our unique technology enables comfortable conversations even in noisy places.

»» Bring Your Own Device (BYOD)

You can use your own mobile phone (including software phones installed in smartphones) as a company extension. And a mobile phone can be paired with your desk phone as one numbered extension.

»» Conferences

Voice conferences with up to 32 members are possible using your desk phone, cellular phone, or software phone.



Am

Creating new
business styles

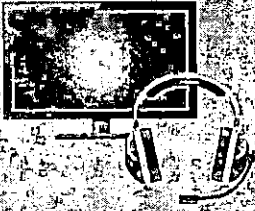

Call Centre

Improvements can be continuously made.

» Automatic Voice Guidance for Customers

Voice guidance is available for callers. Announcement of expected waiting time is also available. Callers can leave a voice message when they do not want to wait.

» Automatic Recording for Supervisors

Conversations with customers can be automatically recorded. The supervisor can search for recording files and listen to the voice recording by logging-in to the PBX built-in web server.

» ACD Report (Call Status Monitor)

The supervisor can monitor the live status of the Call Centre by logging-in to the PBX built-in web server. Call Centre reports are also available.



Jim

Creating new
business styles

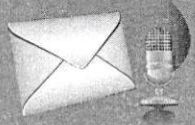

Messaging

Reliable response even while you're away.

» Unified Messages

Incoming calls can be received by a unified message during your absence. Voice messages that are left can be e-mailed to a PC or smartphone.

» Voice Recording

You can also record conversations. Up to 24 simultaneous calls with a maximum of 400 hours of conversation can be recorded.

» Recording Back-up

Back up voice data to USB memory or an external server (NAS*).

* NAS: Network Attached Storage.

W/S

STANDARD: Comply with ANSI/EIA RS-310-D, IEC297-2, DIN41494 ;

PART1, DIN41494; PART7, GB/T3047; 2-92STANDARD.

Specifications

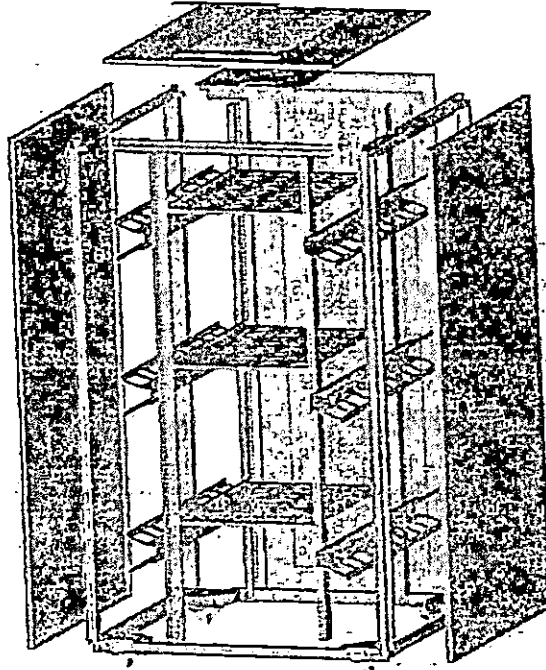

Model No	Capacity (U)	Width (mm)	Depth (mm)	Height (mm)	Packing dimension W*D*H	Volume (CBM)
GN-002-6618	18	600	600	988	630*630*1008	0.3844
GN-002-6622	22	600	600	1166	630*630*1176	0.4459
GN-002-6627	27	600	600	1388	630*630*1403	0.5189
GN-002-6632	32	600	600	1610	630*630*1625	0.6266
GN-002-6642	42	600	600	2055	630*630*2070	0.7881

Definition of Color

Color	
RAL9004	Black

ym

GN-006 WALL MOUNTED NETWORK CABINET

Structure

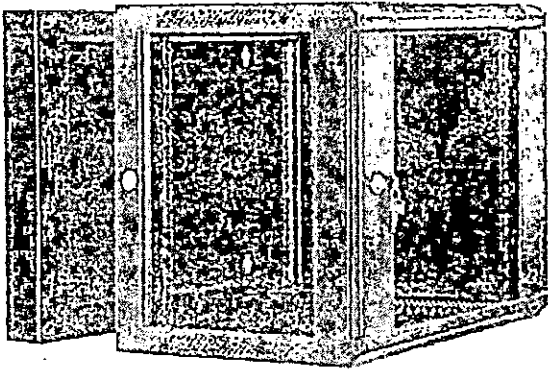

Product Description

- Double section wall mounted cabinet.
- Quick open side door easy to install and maintain.
- Top and bottom wire path.
- Optional caster and support feet for stand installing.
- Optional 120mm axial motor.
- Convenient and quick wall mounting.

Product Information

- Welded frame, reliable structure.
- Double section wall mount cabinet.
- Standing or wall mounting installation.
- Adjustable feet and heavy duty castors are optional.
- Easy mount installation.
- 19" standard installation.
- Removable side panels, side locks optional.
- Cable entry on both of top cover and bottom panel.

Offering Accessories: 20 sets cage nuts.

Main material: SPCC cold rolled steel; **Thickness of Steel:** mounting profile: 1.5mm; others: 1.2mm.
Surface finish: Surface: degreasing, acid pickling, phosphoric, dip-coat primed, powder coat;
Loading capacity: Static loading 60KG **Degree of protection:** IP20.

Specifications

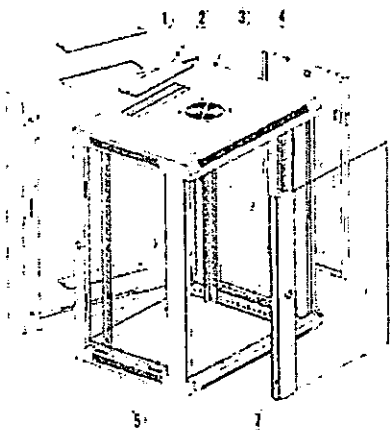

Model No	Capacity (U)	Width (mm)	Depth (mm)	Height (mm)	Packing dimension W*D*H	Volume (CBM)
GN-006-6606	6	600	600	368	630*630*388	0.1937
GN-006-6509	9	600	550	501	630*570*521	0.2923
GN-006-6609	9	600	600	501	630*630*521	0.2923

Definition of Color

Color	
RAL9004	Black

YM

Technology with a
future perspective.

Unified Communication

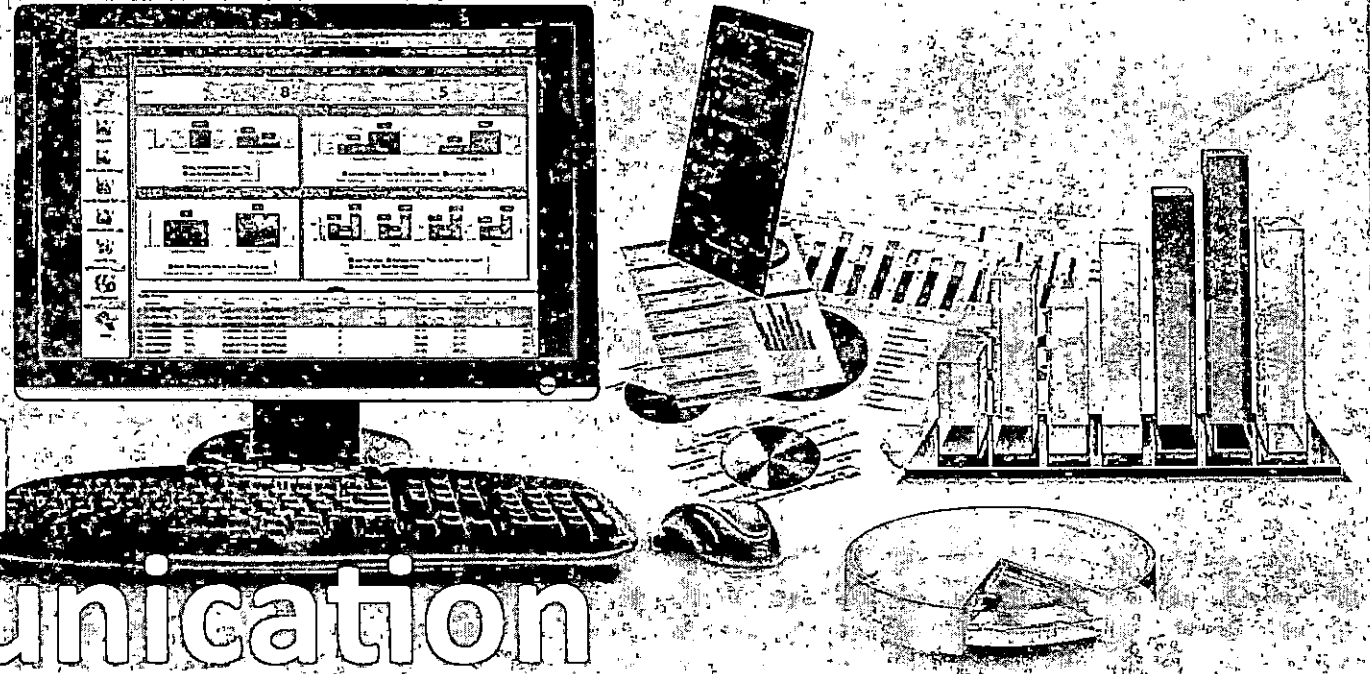

Providing optimal communication.

» Desktop Communication

The status of employees can be checked from a PC, so you can use the most suitable and easiest contact method, such as telephone (land line or mobile), chat, or e-mail. You can also use CRM database integration.

» Anywhere Communication

See the presence of co-workers in remote rooms or branches from a smartphone,* just as you do with a PC.

» Video Communication

Video communication can also be used for more detailed conversations by viewing facial expressions.

* Supported by Version 2 or later.

08

Introduction

Index

Cost Saving

Creating new
business styles

Technology with a
future perspective

Simplified
Maintenance

Terminal
Lineup

wp

Technology with a future perspective

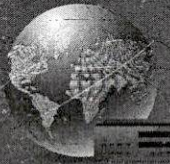

Future Proof



Office Communication Links and Expands Capabilities.

» Expanding Extensions

Adding the Panasonic KX-NS1000 further expands the system capacity at low cost, providing the use of up to 1,000 extensions. What's more, you can continue to use your existing phones and other equipment.

» Multi Site Connection with the KX-NS Series

Connection of KX-NS1000 and KX-NS500 sites allows the use of up to 1,000 extensions, and all sites can be managed by a single KX-NS1000 (one-lock networking).

» Expansion to More than 1,000 Extensions

By connecting sites using conventional methods without one-lock networking, it is possible to use more than 1,000 extensions.

fm

Maintenance



Simplified Maintenance

Easy to set-up,
ready to use.

» No special costs or
labour required

You don't need any special tools, because settings are made by Panasonic devices or PCs based on web maintenance.

» Easy enough for
anyone to set up

You can make settings with the same easy operation as previous models, so setup is quick and easy.

WA



wp

Choose from three series of terminals to match your office style. Regardless of the one you select, you'll enjoy the same elegant, easy-to-use Panasonic performance.



Panasonic provides you with the

ideal workstyle.

» KX-NT Series
IP proprietary terminal



» KX-DT Series
DIGITAL proprietary terminal



» KX-UT Series
SIP telephone

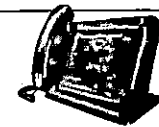

» KX-TCA Series
DECT Terminal



Terminal Lineup

IP PROPRIETARY TERMINAL KX-NT Series

For all businesses that require advanced communication



- High Definition "HD" Audio
- Full Duplex Speakerphone

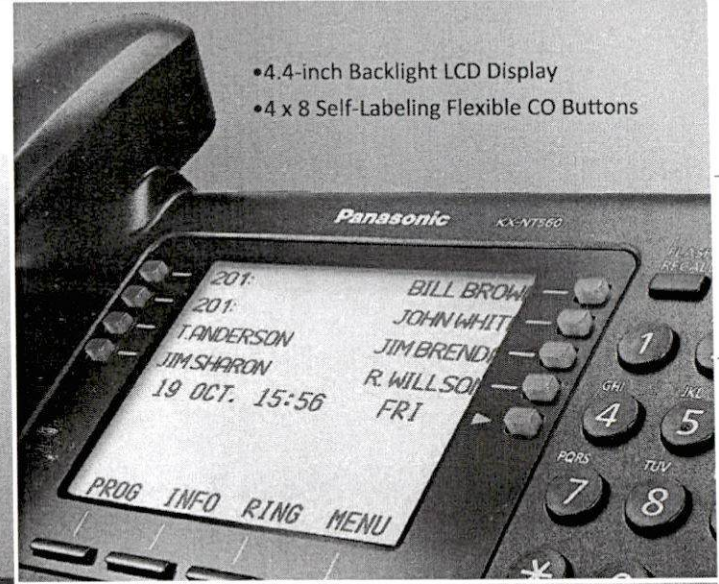

- 4.4-inch Backlight LCD Display
- 4 x 8 Self-Labeling Flexible CO Buttons



- 2 Gigabit Ethernet Port/PoE



- EHS Support
- Integrated Bluetooth®

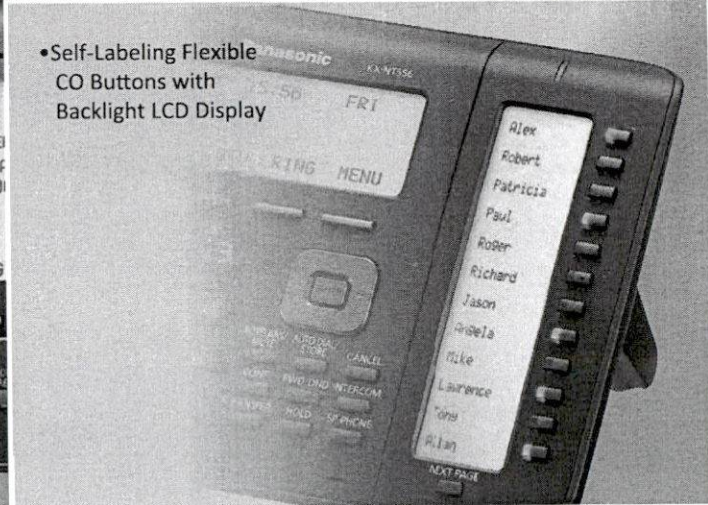

- Self-Labeling Flexible CO Buttons with Backlight LCD Display

Key Features

- HD Voice
- Full Duplex Speakerphone
- Gigabit Ethernet
- PoE
- Large Display with Backlight
- Self-Labeling Flexible CO Button
- EHS Support
- Built-in Bluetooth*

*Some functions are not supported by some models.

Terminal
Lineup

DIGITAL PROPRIETARY
TERMINAL
KX-DT Series



Key Features

- Full Duplex Speakerphone
- Large Display with Backlight
- Flexible CO Button
- EHS Support

*Some functions are not supported by some models.

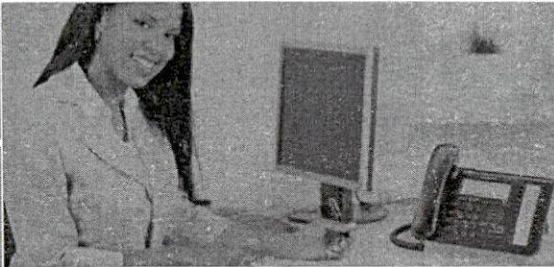

High-quality communication
with high cost-performance



•6-Line Backlight LCD Display

•Full Duplex Speakerphone

•24 Flexible CO Buttons

•EHS Support

up

SIP TELEPHONE
KX-UT Series



Key Features

- Network Camera Integration
- Application Development
- HD Voice
- Full Duplex Speakerphone
- Gigabit Ethernet
- PoE
- Large Display with Backlight
- Self-Labeling Flexible CO Button
- EHS Support

1) Some functions are not supported by some models

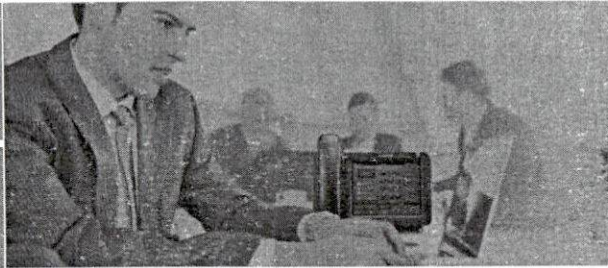

Linking to applications
for optimal communication



- 7 inch Colour Touch Screen
- 4 x 6 Self-Labeling Flexible CO Buttons



- High Definition "HD" Audio
- Full Duplex Speakerphone



• 2 Gigabit Ethernet Port/PoE



• EHS Support

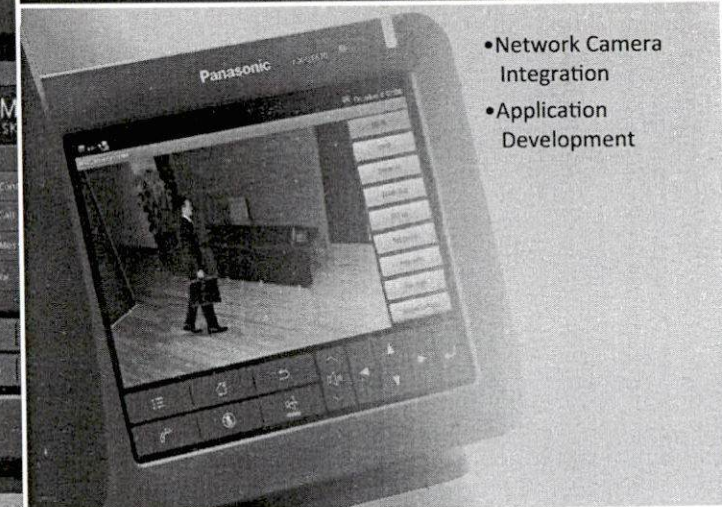

- Network Camera Integration
- Application Development

wf

Terminal
Lineup

DECT TERMINAL
KX-TCA Series

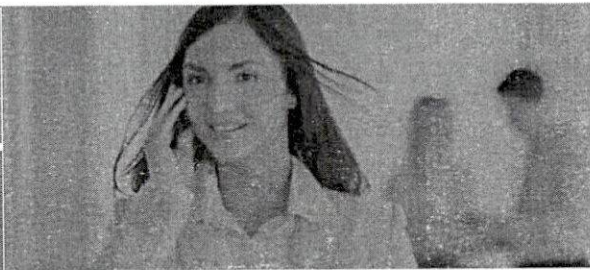

Comfortable and flexible,
on-the-go conversations in
any business style you choose.



15

Introduction



TOUGH MODEL

KX-TCA385

Key Features

- 1.8 inch Colour LCD
- IP65 Compliant Dust Protection and Splash Resistance
- Noise Reduction
- 3 Soft Keys
- Vibration
- Built-in Bluetooth®

Dimensions* (W x D x H) (mm): x55.0 x 23.0 x 151.5
Weight*: 150 g (Belt clip is included)



SLIM & LIGHT MODEL

KX-TCA285

Key Features

- 1.8 inch Colour LCD
- 3 Soft Keys
- Built-in Bluetooth®
- Noise Reduction
- Vibration

Dimensions* (W x D x H) (mm) : 48.5 x 17.9 x 127.5
Weight*: 88 g

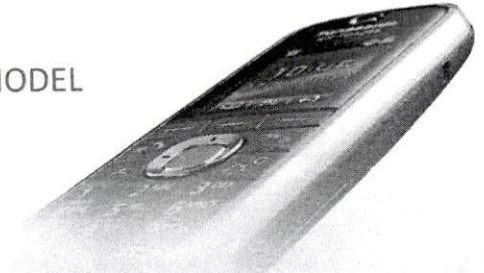

Index

Cost Saving

Creating new
business styles

STANDARD MODEL

KX-TCA185

Key Features

- 1.8 inch Colour LCD
- Noise Reduction
- 3 Soft Keys
- Vibration

Dimensions* (W x D x H) (mm):
48.2 x 25.4 x 146.3
Weight*: 115 g



Technology with a
future perspective

Simplified
Maintenance

Terminal
Lineup

*Handset Only
•Weights and dimensions are approximate.

WLF

POWER OF ATTORNEY

cfm

1. Tender-Securing Declaration

Date: 17th January, 2022

Tender No.: **ME/007/2021-2022/HQ/W/23**

Alternative No.: N/A

To: **MINISTRY OF HEALTH, COMMUNITY DEVELOPMENT,
GENDER, ELDERLY AND CHILDREN**

We, *SOFTNET TECHNOLOGIES LTD*, the undersigned, declare that:

We understand that, according to your conditions, Tenders must be supported by a Tender-Securing Declaration.

We accept that we will automatically be suspended from being eligible for tendering in any contract with the PE for the period of time determined by the Authority, if we are in breach of our obligation(s) under the Tender conditions, because we:

- a) have withdrawn or modified our Tender during the period of tender validity specified in the Form of Tender;
- (b) Disagree to arithmetical correction made to the tender price; or
- (c) have been notified of the acceptance of our Tender by the PE during the period of tender validity, (i) fail or refuse to execute the Contract, if required, failure to sign the contract if required by PE to do so or (ii) fail or refuse to furnish the Performance Security or to comply with any other condition precedent to signing the contract specified in the tendering documents., in accordance with the ITB. We understand this Tender Securing Declaration shall expire if we are not the successful Tenderer, upon the earlier of (i) our receipt of your notification to us of the name of the successful Tenderer; or (ii) twenty-eight days after the expiration of our Tender.

Signed:



Name: **YUSUPH MWAKIMWAGILE - HOD ICT FACILITIES**

Duly authorized to sign the Tender for and on behalf of: **SOFTNET TECHNOLOGIES LTD**

Dated on 17th day of January, 2022

Corporate Seal

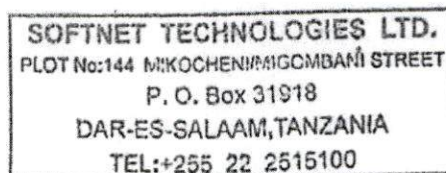

**UNDERTAKING BY TENDERER ON ANTI - BRIBERY POLICY/
CODE OF CONDUCT AND COMPLIANCE PROGRAMME**

(Made under Regulation 78 (2) of GN 446 of 2013)

(Regulation 78(2) of the Public Procurement Regulations, 2013 - Government Notice No. 446 of 2013.)

This company **SOFTNET TECHNOLOGIES LIMITED** places importance on competitive Tendering taking place on a basis that is free, fair, competitive and not open to abuse. It is pleased to confirm that it will not offer or facilitate, directly or indirectly, any improper inducement or reward to any public officer their relations or business associates, in connection with its Tender, or in the subsequent performance of the contract if it is successful.

This company has an Anti-Bribery Policy/Code of Conduct and a Compliance Program which includes all reasonable steps necessary to assure that the No-bribery commitment given in this statement will be complied with by its managers and employees, as well as by all third parties working with this company on the public sector projects, or contract including agents, consultants, consortium partners, sub-contractors and suppliers. Copies of our Anti-Bribery Policy/Code of Conduct and Compliance Program are attached

Authorized Signature:



Name and Title of Signatory: **YUSUPH MWAKIMWAGILE - H.O.D ICT FACILITIES**

Name of Tenderer: **SOFTNET TECHNOLOGIES LIMITED**

Address: **P.O BOX 31918, DAR ES SALAAM**

SOFTNET TECHNOLOGIES LTD.
PLOT No:144 MIKOCHENI/MIGOMBANI STREET
P. O. Box 31918
DAR-ES-SALAAM, TANZANIA
TEL:+255 22 2615100



Anti-Bribery Policy

It is our policy to conduct all of our business in an honest and ethical manner. We take a zero-tolerance approach to bribery and corruption and are committed to acting professionally, fairly and with integrity in all our dealings wherever we operate. We are also committed to implementing and enforcing effective systems to counter bribery.

2 Who is covered by the policy?

This policy applies to all individuals working at all levels and grades, including senior managers, directors, employees (whether permanent, fixed-term or temporary), consultants, contractors, and any other person providing services to us.

3 What is a bribe?

A bribe is a financial or other advantage offered or given:

- to anyone to persuade them to or reward them for performing their duties improperly or;
- to any public official with the intention of influencing the official in the performance of his duties.

4 Gifts and Hospitality

This policy does not prohibit giving and receiving promotional gifts of low value and normal and appropriate hospitality. However, in certain circumstances gifts and hospitality may amount to bribery and all employees must comply strictly with SoftNet's ethics policy in respect of gifts and hospitality. We will not provide gifts or hospitality with the intention of persuading anyone to act improperly or to influence a public official in the performance of his duties.

5 Facilitation payments and kickbacks

We do not make, and will not accept, facilitation payments or "kickbacks" of any kind. Facilitation payments are typically small, unofficial payments made to secure or expedite a routine government action by a government official. Kickbacks are typically payments made in return for a business favour or advantage. All employees must avoid any activity that might lead to, or suggest, that a facilitation payment or kickback will be made or accepted by us.

6 Donations

We do not make contributions of any kind to political parties. No charitable donations will be made for the purpose of gaining any commercial advantage.

7 Record Keeping

7.1 We will keep financial records and have appropriate internal controls in place which will evidence the business reason for making any payments to third parties.

7.2 All expense claims relating to hospitality, gifts or expenses incurred to third parties must be submitted in accordance with our expenses policy and specifically record the reason for the expenditure.

7.3 All accounts, invoices, memoranda and other documents and records relating to dealings with third parties, such as clients, suppliers and business contacts, must be prepared and maintained with strict accuracy and completeness. No accounts must be kept "off-book" to facilitate or conceal improper payments.

8 Raising Concerns

Employees will be encouraged to raise concerns about any issue or suspicion of malpractice at the earliest possible stage. No employee will suffer any detriment as a result of raising genuine concerns about bribery, even if they turn out to be mistaken.

9 Monitoring

The effectiveness of this policy will be regularly reviewed by the Board. Internal control systems and procedures will be subject to audit under the internal audit process.

Anti-Bribery Policy

It is our policy to conduct all of our business in an honest and ethical manner. We take a zero-tolerance approach to bribery and corruption and are committed to acting professionally, fairly and with integrity in all our dealings wherever we operate. We are also committed to implementing and enforcing effective systems to counter bribery.

2 Who is covered by the policy?

This policy applies to all individuals working at all levels and grades, including senior managers, directors, employees (whether permanent, fixed-term or temporary), consultants, contractors, and any other person providing services to us.

3 What is a bribe?

A bribe is a financial or other advantage offered or given:

- to anyone to persuade them to or reward them for performing their duties improperly or;
- to any public official with the intention of influencing the official in the performance of his duties.

4 Gifts and Hospitality

This policy does not prohibit giving and receiving promotional gifts of low value and normal and appropriate hospitality. However, in certain circumstances gifts and hospitality may amount to bribery and all employees must comply strictly with SoftNet's ethics policy in respect of gifts and hospitality. We will not provide gifts or hospitality with the intention of persuading anyone to act improperly or to influence a public official in the performance of his duties.

5 Facilitation payments and kickbacks

We do not make, and will not accept, facilitation payments or "kickbacks" of any kind. Facilitation payments are typically small, unofficial payments made to secure or expedite a routine government action by a government official. Kickbacks are typically payments made in return for a business favour or advantage. All employees must avoid any activity that might lead to, or suggest, that a facilitation payment or kickback will be made or accepted by us.

6 Donations

We do not make contributions of any kind to political parties. No charitable donations will be made for the purpose of gaining any commercial advantage.

7 Record Keeping

7.1 We will keep financial records and have appropriate internal controls in place which will evidence the business reason for making any payments to third parties.

7.2 All expense claims relating to hospitality, gifts or expenses incurred to third parties must be submitted in accordance with our expenses policy and specifically record the reason for the expenditure.

7.3 All accounts, invoices, memoranda and other documents and records relating to dealings with third parties, such as clients, suppliers and business contacts, must be prepared and maintained with strict accuracy and completeness. No accounts must be kept "off-book" to facilitate or conceal improper payments.

8 Raising Concerns

Employees will be encouraged to raise concerns about any issue or suspicion of malpractice at the earliest possible stage. No employee will suffer any detriment as a result of raising genuine concerns about bribery, even if they turn out to be mistaken.

9 Monitoring

The effectiveness of this policy will be regularly reviewed by the Board. Internal control systems and procedures will be subject to audit under the internal audit process.

Anti-Bribery Policy

It is our policy to conduct all of our business in an honest and ethical manner. We take a zero-tolerance approach to bribery and corruption and are committed to acting professionally, fairly and with integrity in all our dealings wherever we operate. We are also committed to implementing and enforcing effective systems to counter bribery.

2 Who is covered by the policy?

This policy applies to all individuals working at all levels and grades, including senior managers, directors, employees (whether permanent, fixed-term or temporary), consultants, contractors, and any other person providing services to us.

3 What is a bribe?

A bribe is a financial or other advantage offered or given:

- to anyone to persuade them to or reward them for performing their duties improperly or;
- to any public official with the intention of influencing the official in the performance of his duties.

4 Gifts and Hospitality

This policy does not prohibit giving and receiving promotional gifts of low value and normal and appropriate hospitality. However, in certain circumstances gifts and hospitality may amount to bribery and all employees must comply strictly with SoftNet's ethics policy in respect of gifts and hospitality. We will not provide gifts or hospitality with the intention of persuading anyone to act improperly or to influence a public official in the performance of his duties.

5 Facilitation payments and kickbacks

We do not make, and will not accept, facilitation payments or "kickbacks" of any kind. Facilitation payments are typically small, unofficial payments made to secure or expedite a routine government action by a government official. Kickbacks are typically payments made in return for a business favour or advantage. All employees must avoid any activity that might lead to, or suggest, that a facilitation payment or kickback will be made or accepted by us.

6 Donations

We do not make contributions of any kind to political parties. No charitable donations will be made for the purpose of gaining any commercial advantage.

7 Record Keeping

7.1 We will keep financial records and have appropriate internal controls in place which will evidence the business reason for making any payments to third parties.

7.2 All expense claims relating to hospitality, gifts or expenses incurred to third parties must be submitted in accordance with our expenses policy and specifically record the reason for the expenditure.

7.3 All accounts, invoices, memoranda and other documents and records relating to dealings with third parties, such as clients, suppliers and business contacts, must be prepared and maintained with strict accuracy and completeness. No accounts must be kept "off-book" to facilitate or conceal improper payments.

8 Raising Concerns

Employees will be encouraged to raise concerns about any issue or suspicion of malpractice at the earliest possible stage. No employee will suffer any detriment as a result of raising genuine concerns about bribery, even if they turn out to be mistaken.

9 Monitoring

The effectiveness of this policy will be regularly reviewed by the Board. Internal control systems and procedures will be subject to audit under the internal audit process.

2. Form of Tender

17th January, 2022

To: MINISTRY OF HEALTH, COMMUNITY DEVELOPMENT, GENDER, ELDERLY AND CHILDREN

We **SOFTNET TECHNOLOGIES LTD**, offer to execute the **TENDER NO: ME/007/2021-2022/HQ/W/23 PROPOSED SUPPLY, INSTALLATION AND COMMISSIONING OF ICT AND SECURITY INSTALLATION WORKS FOR THE COMPLETION CONSTRUCTION OF KATAVI RRH - OPD, DIAGNOSTIC CENTRE AND MATERNITY WING AT MPANDA MUNICIPALITY, KATAVI REGION TANZANIA** in accordance with the Conditions of Contract accompanying this Tender for the Contract Price of **967,635,653.47, VAT INCLUSIVE [Nine hundred sixty seven million six hundred thirty five thousand six hundred fifty three shillings forty seven cents] Tanzanian shillings.**

The Contract shall be paid in the following currencies:

Currency	Percentage payable in currency	Rate of exchange: one foreign equals [<i>insert local</i>]	Inputs for which foreign currency is required
(a)	TZS	N/A	N/A
(b)			

The advance payment required is:-

Amount	Currency
(a)	
(b)	

We declare that our tendering price did not involve agreements with other tenderers for the purpose of tender suppression.

We hereby confirm whoever that shall be **APPOINTED BY NATIONAL CONSTRUCTION COUNCIL** ,to be the Appointing Authority, to appoint the adjudicator in case of any arisen disputes in accordance with ITT 43.1 [Adjudicator]

We are not participating, as tenderers, in more than one Tender in this tendering process other than alternative tenders in accordance with the tendering documents.



Ref: SNT/L/059/2022

02nd March, 2022

Permanent Secretary
Ministry of Health
P.O. BOX 743
Dodoma, Tanzania

RE: TENDER NO: ME/007/2021-2022/HQ/W/23 FOR PROPOSED SUPPLY, INSTALLATION AND COMMISSIONING OF ICT AND SECURITY AT KATAVI (RRH)

SUB: ACCEPTANCE OF OFFER AND AWARD OF CONTRACT

With reference to your letter dated 25th February, 2022 with reference no. CAB 209/549/02/143

Softnet Technologies Limited accept the award of contract for **TENDER NO: ME/007/2021-2022/HQ/W/23 FOR PROPOSED SUPPLY, INSTALLATION AND COMMISSIONING OF ICT AND SECURITY AT KATAVI (RRH)**, at contract price of TZS. 948,754,957.79, (Tanzania Shillings Nine Hundred Forty Eight Million Seven Hundred Fifty Four Thousand Nine Hundred Fifty Seven and Seventy Nine Cents Only) VAT Inclusive.

We appreciate Tender Board for approving and awarding Softnet Technologies Limited this contract. We look forward to work with you and make systems to operate to its optimal condition.

Your Sincerely

SOFTNET TECHNOLOGIES LIMITED

Yours Sincerely,



Yusuph Mwakimwagile
HOD - ICT Facilities



Ref: SNT/L/059/2022

02nd March, 2022

Permanent Secretary
Ministry of Health
P.O. BOX 743
Dodoma, Tanzania

RE: TENDER NO: ME/007/2021-2022/HQ/W/23 FOR PROPOSED SUPPLY, INSTALLATION AND COMMISSIONING OF ICT AND SECURITY AT KATAVI (RRH)

SUB: ACCEPTANCE OF OFFER AND AWARD OF CONTRACT

With reference to your letter dated 25th February, 2022 with reference no. CAB 209/549/02/143

Softnet Technologies Limited accept the award of contract for **TENDER NO: ME/007/2021-2022/HQ/W/23 FOR PROPOSED SUPPLY, INSTALLATION AND COMMISSIONING OF ICT AND SECURITY AT KATAVI (RRH)**, at contract price of TZS. 948,754,957.79, (Tanzania Shillings Nine Hundred Forty Eight Million Seven Hundred Fifty Four Thousand Nine Hundred Fifty Seven and Seventy Nine Cents Only) VAT Inclusive.

We appreciate Tender Board for approving and awarding Softnet Technologies Limited this contract. We look forward to work with you and make systems to operate to its optimal condition.

Your Sincerely

SOFTNET TECHNOLOGIES LIMITED

Yours Sincerely,



Yusuph Mwakimwagile
HOD - ICT Facilities



Ref: SNT/L/059/2022

02nd March, 2022

Permanent Secretary
Ministry of Health
P.O. BOX 743
Dodoma, Tanzania

RE: TENDER NO: ME/007/2021-2022/HQ/W/23 FOR PROPOSED SUPPLY, INSTALLATION AND COMMISSIONING OF ICT AND SECURITY AT KATAVI (RRH)

SUB: ACCEPTANCE OF OFFER AND AWARD OF CONTRACT

With reference to your letter dated 25th February, 2022 with reference no. CAB 209/549/02/143

Softnet Technologies Limited accept the award of contract for **TENDER NO: ME/007/2021-2022/HQ/W/23 FOR PROPOSED SUPPLY, INSTALLATION AND COMMISSIONING OF ICT AND SECURITY AT KATAVI (RRH)**, at contract price of TZS. 948,754,957.79, (Tanzania Shillings Nine Hundred Forty Eight Million Seven Hundred Fifty Four Thousand Nine Hundred Fifty Seven and Seventy Nine Cents Only) VAT Inclusive.

We appreciate Tender Board for approving and awarding Softnet Technologies Limited this contract. We look forward to work with you and make systems to operate to its optimal condition.

Your Sincerely

SOFTNET TECHNOLOGIES LIMITED

Yours Sincerely,



Yusuph Mwakimwagile
HOD - ICT Facilities

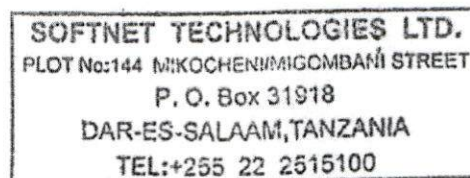

We declare that, as tenderer(s) we do not have conflict of interest with reference to ITT 3.7 [Eligibility of Tenderers]

With reference to ITT 3.11 [Eligibility of Tenderers], it is our intention to subcontract approximately N/A percentage of the Tender /Contract Price, details of which are provided herein.

Our firm, its affiliates or subsidiaries, including any subcontractors or suppliers for any part of the contract has not been declared ineligible by the Government of the United Republic of Tanzania under Tanzania's laws or official regulations or by an act of compliance with a decision of the United Nations Security Council.

The following commissions or gratuities of fees have been paid or are to be paid by us to agents relating to this tender, and to contract execution if we are awarded the contract:-

Name and address of agent or recipient	Amount and currency	Purpose of commission or gratuity
NONE	NONE	NONE

(if none has been paid or is to be paid, state "none")

This tender and your written acceptance of it shall constitute a binding Contract between us.

We understand that you are not bound to accept the lowest or any Tender you receive.

We hereby confirm that this tender complies with the tender validity and Tender Security required by the tendering documents and specified in the Tender Data Sheet.

Authorized Signature:



Name and Title of Signatory: YUSUPH MWAKIMWAGILE - HOD ICT FACILITIES

Name of Tenderer: SOFTNET TECHNOLOGIES LTD

Address: 31918, DAR ES SALAAM



Ref: SNT/L/059/2022

02nd March, 2022

Permanent Secretary
Ministry of Health
P.O. BOX 743
Dodoma, Tanzania

RE: TENDER NO: ME/007/2021-2022/HQ/W/23 FOR PROPOSED SUPPLY, INSTALLATION AND COMMISSIONING OF ICT AND SECURITY AT KATAVI (RRH)

SUB: ACCEPTANCE OF OFFER AND AWARD OF CONTRACT

With reference to your letter dated 25th February, 2022 with reference no. CAB 209/549/02/143

Softnet Technologies Limited accept the award of contract for **TENDER NO: ME/007/2021-2022/HQ/W/23 FOR PROPOSED SUPPLY, INSTALLATION AND COMMISSIONING OF ICT AND SECURITY AT KATAVI (RRH)**, at contract price of TZS. 948,754,957.79, (Tanzania Shillings Nine Hundred Forty Eight Million Seven Hundred Fifty Four Thousand Nine Hundred Fifty Seven and Seventy Nine Cents Only) VAT Inclusive.

We appreciate Tender Board for approving and awarding Softnet Technologies Limited this contract. We look forward to work with you and make systems to operate to its optimal condition.

Your Sincerely

SOFTNET TECHNOLOGIES LIMITED

Yours Sincerely,



Yusuph Mwakimwagile
HOD - ICT Facilities

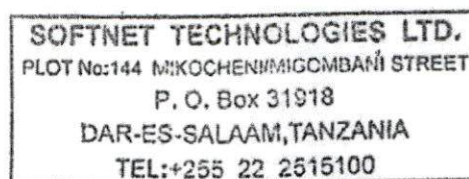

1. Tender-Securing Declaration

Date: 17th January, 2022

Tender No.: **ME/007/2021-2022/HQ/W/23**

Alternative No.: N/A

To: **MINISTRY OF HEALTH, COMMUNITY DEVELOPMENT,
GENDER, ELDERLY AND CHILDREN**

We, *SOFTNET TECHNOLOGIES LTD*, the undersigned, declare that:

We understand that, according to your conditions, Tenders must be supported by a Tender-Securing Declaration.

We accept that we will automatically be suspended from being eligible for tendering in any contract with the PE for the period of time determined by the Authority, if we are in breach of our obligation(s) under the Tender conditions, because we:

- a) have withdrawn or modified our Tender during the period of tender validity specified in the Form of Tender;
- (b) Disagree to arithmetical correction made to the tender price; or
- (c) have been notified of the acceptance of our Tender by the PE during the period of tender validity, (i) fail or refuse to execute the Contract, if required, failure to sign the contract if required by PE to do so or (ii) fail or refuse to furnish the Performance Security or to comply with any other condition precedent to signing the contract specified in the tendering documents., in accordance with the ITB. We understand this Tender Securing Declaration shall expire if we are not the successful Tenderer, upon the earlier of (i) our receipt of your notification to us of the name of the successful Tenderer; or (ii) twenty-eight days after the expiration of our Tender.

Signed:



Name: YUSUPH MWAKIMWAGILE - HOD ICT FACILITIES

Duly authorized to sign the Tender for and on behalf of: SOFTNET TECHNOLOGIES LTD

Dated on 17th day of January, 2022

Corporate Seal



**UNDERTAKING BY TENDERER ON ANTI - BRIBERY POLICY/
CODE OF CONDUCT AND COMPLIANCE PROGRAMME**
(Made under Regulation 78 (2) of GN 446 of 2013)

(Regulation 78(2) of the Public Procurement Regulations, 2013 - Government Notice No. 446 of 2013.)

This company **SOFTNET TECHNOLOGIES LIMITED** places importance on competitive Tendering taking place on a basis that is free, fair, competitive and not open to abuse. It is pleased to confirm that it will not offer or facilitate, directly or indirectly, any improper inducement or reward to any public officer their relations or business associates, in connection with its Tender, or in the subsequent performance of the contract if it is successful.

This company has an Anti-Bribery Policy/Code of Conduct and a Compliance Program which includes all reasonable steps necessary to assure that the No-bribery commitment given in this statement will be complied with by its managers and employees, as well as by all third parties working with this company on the public sector projects, or contract including agents, consultants, consortium partners, sub-contractors and suppliers. Copies of our Anti-Bribery Policy/Code of Conduct and Compliance Program are attached

Authorized Signature:



Name and Title of Signatory: **YUSUPH MWAKIMWAGILE - H.O.D ICT FACILITIES**

Name of Tenderer: **SOFTNET TECHNOLOGIES LIMITED**

Address: **P.O BOX 31918, DAR ES SALAAM**

SOFTNET TECHNOLOGIES LTD. PLOT No:144 MIKOCHENI/MIGOMBANI STREET P. O. Box 31918 DAR-ES-SALAAM, TANZANIA TEL:+255 22 2515100

**UNDERTAKING BY TENDERER ON ANTI - BRIBERY POLICY/
CODE OF CONDUCT AND COMPLIANCE PROGRAMME**
(Made under Regulation 78 (2) of GN 446 of 2013)

*(Regulation 78(2) of the Public Procurement Regulations, 2013 - Government
Notice No. 446 of 2013.)*

This company **SOFTNET TECHNOLOGIES LIMITED** places importance on competitive Tendering taking place on a basis that is free, fair, competitive and not open to abuse. It is pleased to confirm that it will not offer or facilitate, directly or indirectly, any improper inducement or reward to any public officer their relations or business associates, in connection with its Tender, or in the subsequent performance of the contract if it is successful.

This company has an Anti-Bribery Policy/Code of Conduct and a Compliance Program which includes all reasonable steps necessary to assure that the No-bribery commitment given in this statement will be complied with by its managers and employees, as well as by all third parties working with this company on the public sector projects, or contract including agents, consultants, consortium partners, sub-contractors and suppliers. Copies of our Anti-Bribery Policy/Code of Conduct and Compliance Program are attached

Authorized Signature:



Name and Title of Signatory: **YUSUPH MWAKIMWAGILE - H.O.D ICT FACILITIES**

Name of Tenderer: **SOFTNET TECHNOLOGIES LIMITED**

Address: **P.O BOX 31918, DAR ES SALAAM**

SOFTNET TECHNOLOGIES LTD.
PLOT No:144 MIKOCHENI/MIGOMBANI STREET
P. O. Box 31918
DAR-ES-SALAAM, TANZANIA
TEL:+255 22 2515100



**UNDERTAKING BY TENDERER ON ANTI - BRIBERY POLICY/
CODE OF CONDUCT AND COMPLIANCE PROGRAMME**
(Made under Regulation 78 (2) of GN 446 of 2013)

(Regulation 78(2) of the Public Procurement Regulations, 2013 - Government Notice No. 446 of 2013.)

This company **SOFTNET TECHNOLOGIES LIMITED** places importance on competitive Tendering taking place on a basis that is free, fair, competitive and not open to abuse. It is pleased to confirm that it will not offer or facilitate, directly or indirectly, any improper inducement or reward to any public officer their relations or business associates, in connection with its Tender, or in the subsequent performance of the contract if it is successful.

This company has an Anti-Bribery Policy/Code of Conduct and a Compliance Program which includes all reasonable steps necessary to assure that the No-bribery commitment given in this statement will be complied with by its managers and employees, as well as by all third parties working with this company on the public sector projects, or contract including agents, consultants, consortium partners, sub-contractors and suppliers. Copies of our Anti-Bribery Policy/Code of Conduct and Compliance Program are attached

Authorized Signature:



Name and Title of Signatory: **YUSUPH MWAKIMWAGILE - H.O.D ICT FACILITIES**

Name of Tenderer: **SOFTNET TECHNOLOGIES LIMITED**

Address: **P.O BOX 31918, DAR ES SALAAM**

SOFTNET TECHNOLOGIES LTD.
PLOT No:144 MIKOCHENI/MIGOMBANI STREET
P. O. Box 31918
DAR-ES-SALAAM, TANZANIA
TEL:+255 22 2515100



Anti-Bribery Policy

It is our policy to conduct all of our business in an honest and ethical manner. We take a zero-tolerance approach to bribery and corruption and are committed to acting professionally, fairly and with integrity in all our dealings wherever we operate. We are also committed to implementing and enforcing effective systems to counter bribery.

2 Who is covered by the policy?

This policy applies to all individuals working at all levels and grades, including senior managers, directors, employees (whether permanent, fixed-term or temporary), consultants, contractors, and any other person providing services to us.

3 What is a bribe?

A bribe is a financial or other advantage offered or given:

- to anyone to persuade them to or reward them for performing their duties improperly or;
- to any public official with the intention of influencing the official in the performance of his duties.

4 Gifts and Hospitality

This policy does not prohibit giving and receiving promotional gifts of low value and normal and appropriate hospitality. However, in certain circumstances gifts and hospitality may amount to bribery and all employees must comply strictly with SoftNet's ethics policy in respect of gifts and hospitality. We will not provide gifts or hospitality with the intention of persuading anyone to act improperly or to influence a public official in the performance of his duties.

5 Facilitation payments and kickbacks

We do not make, and will not accept, facilitation payments or "kickbacks" of any kind. Facilitation payments are typically small, unofficial payments made to secure or expedite a routine government action by a government official. Kickbacks are typically payments made in return for a business favour or advantage. All employees must avoid any activity that might lead to, or suggest, that a facilitation payment or kickback will be made or accepted by us.

6 Donations

We do not make contributions of any kind to political parties. No charitable donations will be made for the purpose of gaining any commercial advantage.

7 Record Keeping

7.1 We will keep financial records and have appropriate internal controls in place which will evidence the business reason for making any payments to third parties.

7.2 All expense claims relating to hospitality, gifts or expenses incurred to third parties must be submitted in accordance with our expenses policy and specifically record the reason for the expenditure.

7.3 All accounts, invoices, memoranda and other documents and records relating to dealings with third parties, such as clients, suppliers and business contacts, must be prepared and maintained with strict accuracy and completeness. No accounts must be kept "off-book" to facilitate or conceal improper payments.

8 Raising Concerns

Employees will be encouraged to raise concerns about any issue or suspicion of malpractice at the earliest possible stage. No employee will suffer any detriment as a result of raising genuine concerns about bribery, even if they turn out to be mistaken.

9 Monitoring

The effectiveness of this policy will be regularly reviewed by the Board. Internal control systems and procedures will be subject to audit under the internal audit process.

Anti-Bribery Policy

It is our policy to conduct all of our business in an honest and ethical manner. We take a zero-tolerance approach to bribery and corruption and are committed to acting professionally, fairly and with integrity in all our dealings wherever we operate. We are also committed to implementing and enforcing effective systems to counter bribery.

2 Who is covered by the policy?

This policy applies to all individuals working at all levels and grades, including senior managers, directors, employees (whether permanent, fixed-term or temporary), consultants, contractors, and any other person providing services to us.

3 What is a bribe?

A bribe is a financial or other advantage offered or given:

- to anyone to persuade them to or reward them for performing their duties improperly or;
- to any public official with the intention of influencing the official in the performance of his duties.

4 Gifts and Hospitality

This policy does not prohibit giving and receiving promotional gifts of low value and normal and appropriate hospitality. However, in certain circumstances gifts and hospitality may amount to bribery and all employees must comply strictly with SoftNet's ethics policy in respect of gifts and hospitality. We will not provide gifts or hospitality with the intention of persuading anyone to act improperly or to influence a public official in the performance of his duties.

5 Facilitation payments and kickbacks

We do not make, and will not accept, facilitation payments or "kickbacks" of any kind. Facilitation payments are typically small, unofficial payments made to secure or expedite a routine government action by a government official. Kickbacks are typically payments made in return for a business favour or advantage. All employees must avoid any activity that might lead to, or suggest, that a facilitation payment or kickback will be made or accepted by us.

6 Donations

We do not make contributions of any kind to political parties. No charitable donations will be made for the purpose of gaining any commercial advantage.

7 Record Keeping

7.1 We will keep financial records and have appropriate internal controls in place which will evidence the business reason for making any payments to third parties.

7.2 All expense claims relating to hospitality, gifts or expenses incurred to third parties must be submitted in accordance with our expenses policy and specifically record the reason for the expenditure.

7.3 All accounts, invoices, memoranda and other documents and records relating to dealings with third parties, such as clients, suppliers and business contacts, must be prepared and maintained with strict accuracy and completeness. No accounts must be kept "off-book" to facilitate or conceal improper payments.

8 Raising Concerns

Employees will be encouraged to raise concerns about any issue or suspicion of malpractice at the earliest possible stage. No employee will suffer any detriment as a result of raising genuine concerns about bribery, even if they turn out to be mistaken.

9 Monitoring

The effectiveness of this policy will be regularly reviewed by the Board. Internal control systems and procedures will be subject to audit under the internal audit process.

Anti-Bribery Policy

It is our policy to conduct all of our business in an honest and ethical manner. We take a zero-tolerance approach to bribery and corruption and are committed to acting professionally, fairly and with integrity in all our dealings wherever we operate. We are also committed to implementing and enforcing effective systems to counter bribery.

2 Who is covered by the policy?

This policy applies to all individuals working at all levels and grades, including senior managers, directors, employees (whether permanent, fixed-term or temporary), consultants, contractors, and any other person providing services to us.

3 What is a bribe?

A bribe is a financial or other advantage offered or given:

- to anyone to persuade them to or reward them for performing their duties improperly or;
- to any public official with the intention of influencing the official in the performance of his duties.

4 Gifts and Hospitality

This policy does not prohibit giving and receiving promotional gifts of low value and normal and appropriate hospitality. However, in certain circumstances gifts and hospitality may amount to bribery and all employees must comply strictly with SoftNet's ethics policy in respect of gifts and hospitality. We will not provide gifts or hospitality with the intention of persuading anyone to act improperly or to influence a public official in the performance of his duties.

5 Facilitation payments and kickbacks

We do not make, and will not accept, facilitation payments or "kickbacks" of any kind. Facilitation payments are typically small, unofficial payments made to secure or expedite a routine government action by a government official. Kickbacks are typically payments made in return for a business favour or advantage. All employees must avoid any activity that might lead to, or suggest, that a facilitation payment or kickback will be made or accepted by us.

6 Donations

We do not make contributions of any kind to political parties. No charitable donations will be made for the purpose of gaining any commercial advantage.

7 Record Keeping

7.1 We will keep financial records and have appropriate internal controls in place which will evidence the business reason for making any payments to third parties.

7.2 All expense claims relating to hospitality, gifts or expenses incurred to third parties must be submitted in accordance with our expenses policy and specifically record the reason for the expenditure.

7.3 All accounts, invoices, memoranda and other documents and records relating to dealings with third parties, such as clients, suppliers and business contacts, must be prepared and maintained with strict accuracy and completeness. No accounts must be kept "off-book" to facilitate or conceal improper payments.

8 Raising Concerns

Employees will be encouraged to raise concerns about any issue or suspicion of malpractice at the earliest possible stage. No employee will suffer any detriment as a result of raising genuine concerns about bribery, even if they turn out to be mistaken.

9 Monitoring

The effectiveness of this policy will be regularly reviewed by the Board. Internal control systems and procedures will be subject to audit under the internal audit process.

**UNDERTAKING BY TENDERER ON ANTI - BRIBERY POLICY/
CODE OF CONDUCT AND COMPLIANCE PROGRAMME**
(Made under Regulation 78 (2) of GN 446 of 2013)

(Regulation 78(2) of the Public Procurement Regulations, 2013 - Government Notice No. 446 of 2013.)

This company **SOFTNET TECHNOLOGIES LIMITED** places importance on competitive Tendering taking place on a basis that is free, fair, competitive and not open to abuse. It is pleased to confirm that it will not offer or facilitate, directly or indirectly, any improper inducement or reward to any public officer their relations or business associates, in connection with its Tender, or in the subsequent performance of the contract if it is successful.

This company has an Anti-Bribery Policy/Code of Conduct and a Compliance Program which includes all reasonable steps necessary to assure that the No-bribery commitment given in this statement will be complied with by its managers and employees, as well as by all third parties working with this company on the public sector projects, or contract including agents, consultants, consortium partners, sub-contractors and suppliers. Copies of our Anti-Bribery Policy/Code of Conduct and Compliance Program are attached

Authorized Signature:



Name and Title of Signatory: **YUSUPH MWAKIMWAGILE - H.O.D ICT FACILITIES**

Name of Tenderer: **SOFTNET TECHNOLOGIES LIMITED**

Address: **P.O BOX 31918, DAR ES SALAAM**

SOFTNET TECHNOLOGIES LTD. PLOT No:144 MIKOCHENI/MIGOMBANI STREET P. O. Box 31918 DAR-ES-SALAAM, TANZANIA TEL:+255 22 2515100



**UNDERTAKING BY TENDERER ON ANTI - BRIBERY POLICY/
CODE OF CONDUCT AND COMPLIANCE PROGRAMME**

(Made under Regulation 78 (2) of GN 446 of 2013)

(Regulation 78(2) of the Public Procurement Regulations, 2013 - Government Notice No. 446 of 2013.)

This company **SOFTNET TECHNOLOGIES LIMITED** places importance on competitive Tendering taking place on a basis that is free, fair, competitive and not open to abuse. It is pleased to confirm that it will not offer or facilitate, directly or indirectly, any improper inducement or reward to any public officer their relations or business associates, in connection with its Tender, or in the subsequent performance of the contract if it is successful.

This company has an Anti-Bribery Policy/Code of Conduct and a Compliance Program which includes all reasonable steps necessary to assure that the No-bribery commitment given in this statement will be complied with by its managers and employees, as well as by all third parties working with this company on the public sector projects, or contract including agents, consultants, consortium partners, sub-contractors and suppliers. Copies of our Anti-Bribery Policy/Code of Conduct and Compliance Program are attached

Authorized Signature:



Name and Title of Signatory: **YUSUPH MWAKIMWAGILE - H.O.D ICT FACILITIES**

Name of Tenderer: **SOFTNET TECHNOLOGIES LIMITED**

Address: **P.O BOX 31918, DAR ES SALAAM**

SOFTNET TECHNOLOGIES LTD.
PLOT No:144 MIKOCHENI/MIGOMBANI STREET
P. O. Box 31918
DAR-ES-SALAAM, TANZANIA
TEL:+255 22 2515100



STANDARD POWER OF ATTORNEY

TO ALL IT MAY CONCERN

THAT BY THIS POWER OF ATTORNEY given on this 19 day of 01..... 2022.

We, the undersigned SOFTNET TECHNOLOGY LIMITED whose office is at Plot No 144, MIGOMBANI STREET, within KINONDONI MUNICIPALITY, P.O. BOX 31918, DAR ES SALAAM by virtue of authority conferred to us by the Board Resolution No. 01 of 02nd day of Jan 2022 do hereby ordain nominate and appoint YUSUPH MWAKIMWAGILE of P.O. BOX 31918, DAR ES SALAAM to be our true lawful Attorney and Agent, with full power and authority, for us and in our names, and for our accounts and benefits, to do any, or all of the following acts, in the execution of Tender No. ME/007/2021-2022/HQ/W/23 FOR PROPOSED SUPPLY, INSTALLATION AND COMMISSIONING OF ICT AND SECURITY INSTALLATION WORKS FOR THE COMPLETION CONSTRUCTION OF KATAVI RRH-OPD, DIAGNOSTIC CENTRE AND MATERNITY WING issued by Ministry of Health, Community Development, Gender, Elderly and Children;

AND provided always that this Power of Attorney shall not revoke or in any manner affects any future power of attorney given to any other person or persons for such other power or powers shall remain and to be of the same force and affect as if this deed has not been executed.

AND we hereby undertake to ratify everything, which our Attorney or any substitute or substitutes or agent or agents appointed by him under this power on his behalf herein before contained shall do or purport to do in virtue of this Power of Attorney.

SEALED with the Common Seal of the said SOFTNET TECHNOLOGY LIMITED delivered in the presence of us this 19 day of 01..... 2022.

Wherefore we have signed this deed on this 19 day of 01..... 2022 at Dar es Salaam for and on behalf of SOFTNET TECHNOLOGY LIMITED

SEALED and DELIVERED by COMMON SEAL OF THE
SOFTNET TECHNOLOGIES LIMITED by GILBERT HERMAN
this 19 day of 01..... 2022

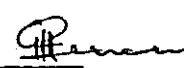
DONOR

BEFORE ME:-

NAME: MESWIN JOSEPH MASINGA

SIGNATURE: [Signature]

DATE: 14th January 2022

DESIGNATION: COMMISSIONER FOR OATHS

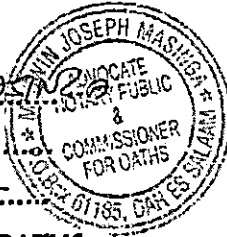

ACKNOWLEDGEMENT

I, YUSUPH MWAKIMWAGILE of P.O. BOX 31918, DAR ES SALAAM doth hereby acknowledge and accept to be Attorney of the said SOFTNET TECHNOLOGIES LIMITED under the terms and conditions contained in this POWER OF ATTORNEY and I promise to perform and discharge my duties as the lawfully appointed attorney faithfully and honestly.

SIGNED and DELIVERED by YUSUPH

MWAKIMWAGILE who is identified to me by

_____ the latter known to me

Personally this 14 day of 01 2022

[Signature]

DONEE

BEFORE ME:-

NAME: MESWIN JOSEPH MASINGA

SIGNATURE: [Signature]

DATE: 14th January 2022

